



FILTER



DIVISION



[www.brauersupply.com](http://www.brauersupply.com)

1-800-392-8776





Brauer Supply is the complete filter center serving Missouri, Illinois and Kansas. We represent only the finest quality established names in the industry.

Our twelve locations are conveniently located near your place of business with our fleet of modern delivery trucks ready to bring material directly to you from an extensive inventory of pleated filters, fiberglass throw aways, bag filters, final filters, HEPA filters, belts, water and air cartridges and more. Additionally, our application specialists are available for on-site visits to help you find solutions to your filter problems.

Our state-of-the-art warehousing facility can meet your needs for “Just-In-Time” delivery. We provide the convenience of purchase order consolidation as well as fast turn around in our on site filter fab shop. Our 130+ year history provides buying power with manufacturers to insure that you receive competitive pricing and can obtain filters even in times of product shortage.

Brauer Supply is an acknowledged source for a wide range of industrial products in addition to filters. For a complete listing of lines we carry, visit [www.brauersupply.com](http://www.brauersupply.com) or call one of our product specialists.

We invite you to review the pages that follow to see how we can help your bottom line.

Give us a call at 314-534-7150 or 1-800-392-8776 to talk to your customer service specialist today.

We look forward to working with you!



# Table of Contents

Leed Green	5
Brauer Supply History	5-8
Applications	9
Efficiency Guide	10
Fiberglass Disposable Filters With Metal Grille	11-12
Fiberglass disposable Pinch Frame	13-14
MX40 Standard Capacity Pleats - Airguard	14-15
DP40 High Capacity Pleats - Airguard	16-17
Xtreme Pleats - Airguard	17-18
Powerguard Pleats - Airguard	18--19
DP13 MERV 13 Pleats - Airguard	19-20
Specialty Pleats - Airguard	21
XL8-SC Standard Capacity Pleats - Koch	22-23
XL8-HC High Capacity Pleats - Koch	23-24
Specialty Pleats - Koch	25-26
3M	26-31
Permalast	32
Foam	33
Slip On Service Rolls	33-34
Aluminum Washable	34
Poly Pads and Rolls	35-38
Autorolls	38-42
Polyester Panels and Links	43-44
Bag Filters	44-47
Final Filters - Airguard	48-50
Final Filters - Koch	51-53
Service Rolls	53-54
HEPAs - Airguard	54-55
HEPAs - Koch	55-56
Gas Phase Filters	56-57
Paint Spray Booth Filters	58-72
Ultraviolet Light	73
Pan Pills	73
V-Belt	74
Everpure/Pentair	75
Harmsco	76
Internally Supported Filters	77
Holding Frames & Latches	77
Housing	78-83
Permatron	84-87
Custom Filter Order form	88
Filter Selection Options	89-90
Brauer Supply General Terms	91-92





## Brauer has Many LEED GREEN Associates

The LEED (Leadership in Energy and Environmental Design) is a ratings system that certifies buildings as meeting established standards of energy sustainability and environmental friendliness, both in their interior environments and in their effect on the surrounding ecology. It was created by the United States Green Building Council (USGBC), a nonprofit organization founded in 1993 to promote sustainable, environmentally friendly building design. A building or construction project that receives a sufficiently high score on the USGBC's LEED checklist is awarded a certificate signifying its level of compliance with the LEED standards. Depending on the degree to which a building project meets the standards, it can be awarded anything from a simple certificate for a minimum level of compliance to a platinum certificate for meeting the highest possible standards.



## Brauer Supply History

Since 1881, the Brauer Supply Company has served the midwest marketplace. The company's story is one that parallels the development of the region itself and the emergence of the heating and cooling and related industries through many technical innovations. Yet, the same factors which originally caused the company to prosper...service, dependability, and a fair price...are the same which help to place Brauer Supply Company in a position of leadership today.

The story of Brauer Supply Company begins in 1881. The City of St. Louis was entering one of its most exciting periods as its location on the Mississippi River turned into a national center of commerce. Riverboats in great numbers were bringing people and goods from the East via the Ohio River and to and from New Orleans to the South. The frontier was still very much alive and St. Louis served as a supply point for adventurers and settlers heading West. Also, at the time, the country was in the midst of the Industrial Revolution and the idea of standardized replacement parts for manufactured goods was becoming widely accepted.

A major industry of the period was manufacturing of cast iron heating stoves of all varieties. Quite a number of makes and types of these stoves were produced in the East for shipment to dealers in the western and rural regions of the country. When inevitably, repair parts were needed, the dealer in each locality had to leaf through many different catalogs and send several different orders for the various parts. There were often long time delays and expensive shipping charges which had to be paid.

The Brauer staff is here shown in 1884 in front of the Company's second location. A.G. Brauer is the third man from the right



The need for a central source of supply which could furnish all parts for all stoves at a savings of time and money to the dealer was recognized by the young August G. Brauer.

Mr. Brauer had worked as a salesman for a local manufacturer of coal and wood burning stoves, eventually becoming manager of that business. When one of the owners passed away and the firm was about to fold, Mr. Brauer, feeling an obligation to his customers to provide the replacement parts they needed, found himself at the head of his own business supplying these parts.

August Brauer was surprised as anyone else that his little enterprise began to flourish in the small shop on St. Ann's Street, East of Broadway. In fact, he soon was doing so well at this business of servicing the heating stoves of the St. Louis area with repairs and replacement parts that he began to expand. In 1884, he purchased the St. Louis Stove Repair Works on Franklin Avenue, and moved into a new and larger location at 217 to 219 Locust where he made arrangements to become the representative for parts and repairs for The Charter Oak Stove & Range Company, Bridge and Beach Manufacturing Company, and Bucks Stove and Range Company

The general growth and expansion in the field continued until about 1923 when the Company decided to make an important change with the times. That change was taking on the repair parts of warm air furnaces as well as the heating stoves which were then beginning to dwindle as central heating became the new thing. It was in 1907 that the firm was incorporated as the A.G. Brauer Supply Company with August Brauer as president; John Schuricht as secretary and treasurer; and Julius Hartig as manager.

By 1930, a filter had been developed for hot-air furnaces to keep the dust of the basement heating unit from penetrating into other sections of the house. Brauer became the first distributor in the nation for this new development in heating systems. Some of their competitors laughed at them for taking on such a novelty which they said would never amount to anything - yet - without the filter, today's air conditioning systems would be unable to operate.

The year 1932 marked the passing of the founder of the company, August G. Brauer. He died of pneumonia on September 23. One month later his son, Oscar P. Brauer, assumed the presidency of the firm.

The Company made great strides during the period of Oscar Brauer's leadership, expanding both its products and its markets. Brauer Supply also assumed a position of leadership in the industry nationally as Oscar P. Brauer was a founder and president of the North American Heating and Air Conditioning Wholesalers Association and a member of the Board of Trustees of the National Association of Wholesalers.

During the 1930's, the Company was forced out of its headquarters on Third Street by the Jefferson National Expansion Memorial Project, and it was in 1940 that it moved to a five-story building at 2100 Washington. There it occupied 65000sq ft of floor space crammed with an inventory of heating, air-conditioning, and hot-water equipment plus replacement parts for at least sixty different manufacturers' heating stoves. Water heaters and the fittings, pipes, and parts to make them work.

William H. Brauer, grandson of the founder, joined the firm in 1953 after five years in the sales department of Monsanto Chemical. A chemical engineering graduate of M.I.T., Bill Brauer developed the Company's insulation division which today features a complete line of industrial insulation materials covering a wide range of uses and conditions.



This was Brauer Supply in the early 1900's.



2100 Washington was home to Brauer Supply in the 40's, 50's, and 60's.

The insulation division was housed then in a separate facility located at 330 South Newstead with facilities for office space as well as customer pick-up and rail siding.

As the Company became identified as a long-established family-business, the Board of Directors decided in June of 1957 to drop the "A.G." from the name and it became simply, the "Brauer Supply Company."

In 1965 the firm opened its first branch office outside of the City of St. Louis in Sikeston, Missouri. Shortly thereafter it was moved to Cape Girardeau. Now located in Jackson, Missouri, this location provides coverage for the Southeast Missouri market area.

In 1968 Oscar Brauer passed the reins as president to William H. Brauer, assisted ably by long-tenured Vice-President Leonard H. Troeller. Oscar Brauer remained an active advisor to the business until his death in 1977.

A fourth division - fasteners - was expanded in 1970 to complement the already strong heating, filters, and insulation departments. Brauer soon became a major supplier of rivets, twist drills, self-drilling screws and other specialty fasteners. Maintaining a staff with a high level of technical expertise, Brauer Supply is a source of information and advice to the customer with fastening needs.

In 1972 continued growth forced the Company to expand its headquarters once again, moving to 4260 Forest Park. There, a large, modern warehouse with fully-mechanized materials handling equipment helped to ensure speedy order filling and prompt shipment to customers. A fleet of delivery trucks is available for daily runs in the St. Louis, Columbia, Jackson, Joplin, and Springfield, Missouri and Illinois areas.

In 1978, James Truesdell, representing the fourth generation of Brauer family, joined the company.

Brauer's centennial year, 1981, saw the installation of a modern, computer-based accounting system which provided greater ability to stock those items customers need most and to provide clear and concise orders, invoices, and other information to increase service levels.

Growth accelerated in 1984 with the opening of a new branch office in Columbia, Missouri. That same year saw the acquisition of a large warehouse adjacent to the Brauer St. Louis headquarters to insure room for future expansion.

William D. Brauer, great-grandson of the founder, joined the firm in 1985 after serving as a pilot in the United States Navy.

In the Fall of 1989, the company added 23,000 square feet of warehouse space and multiple docks for shipping and receiving at its main location. At the same time, James Truesdell was named the company's fourth President, and William D. Brauer assumed the duties of Vice President. Shortly after this, an enhanced computer system was installed, and branches were added in Swansea, Illinois, and St. Peters, Washington, and Festus, Missouri.

In 1996, Robert G. Brauer, second son of William H. Brauer, joined the Company after serving in marketing positions with the Sherwin-Williams Company. Continued growth followed with the opening of a branch office in Joplin, Missouri. Two years later a store was opened in Springfield, Missouri.

In 2002, Brauer Supply took a leading role as James Truesdell chaired the industry group founding the Heating, Air Conditioning, and Refrigeration Distributors International (HARDI) which is today the HVAC distribution industry's leading voice.

In 2005, the St. Louis headquarters was expanded, and the Company's eleventh location, in Springfield, Illinois, opened its doors.

Finally, in early 2010, the headquarters was moved to a modern, single story distribution center at 1218 South Vandeventer. Here all products are distributed throughout the company's network of service centers, including a large facility opened at the same time to serve the Kansas City metro area.

In its third century, Brauer Supply is no longer a company geared to one segment of industry. Brauer is a broad-based industrial supplier with products needed by almost all areas of the business community. The family tradition of service and customer satisfaction remains the prime focus. The Company motto, "In Business to Serve You!", is a constant reminder that the customer is the reason for our success and even our very existence.



August G. Brauer, founder and president from 1881-1932



Oscar P. Brauer, son of the founder and second president



Currently active Brauer Family members include: President James L. Truesdell and Chairman William H. Brauer (seated) and Vice President Robert G. Brauer and Vice President William D. Brauer (standing).



# Applications



◀ Malls



Schools ▶



◀ Hospital, pharmaceutical, and clean room applications

Office buildings, sports arenas, and commercial facilities of all types ▶



◀ Industrial plants and gas turbine applications



Paint overspray and industrial finishing applications ▶



◀ Airports, museums and other carbon and gas phase filtration applications



# Efficiency Selection Guide

Standard 52.5 Minimum Efficiency Reporting Value	Dust Spot Efficiency	Arrestance	Typical Controlled Contaminant	Typical Applications and Limitations	Typical Air Filter/Cleaner Type
20	n/a	n/a	< 0.30 pm particle size	Cleanrooms	≥99.999% eff. On .10-.20 pm Particles
19	n/a	n/a	Virus (unattached)	Radioactive Materials	Particulates
18	n/a	n/a	Carbon Dust	Pharmaceutical Man.	Particulates
17	n/a	n/a	All Combustion smoke	Carcinogenetic Materials	≥99.97% eff. On .30 pm Particles
16	n/a	n/a	.30-1.0 pm Particle Size	General Surgery	<b>Bag Filter</b> - Nonsupported microfine fiberglass or synthetic media, 12-36 in. deep, 6-12 pockets <b>Box Filter</b> - Rigid Style Cartridge Filters 6 to 12" deep may use lofted or paper media.
15	>95%	n/a	All Bacteria	Hospital Inpatient Care	
14	90-95%	>98%	Most Tobacco Smoke	Smoking Lounges	
13	89-90%	>98%	Proplet Nuceli (Sneeze)	Superior Commercial Buildings	
12	70-75%	>95%	1.0-3.0 pm Particle Size Legionella	Superior Residential	<b>Bag Filter</b> - Nonsupported microfine fiberglass or synthetic media, 12-36 in. deep, 6-12 pockets <b>Box Filter</b> - Rigid Style Cartridge Filters 6 to 12" deep may use lofted or paper media.
11	60-65%	>95%	Humidifier Dust Lead Dust	Better Commercial Buildings	
10	50-55%	>95%	Milled Flour Auto Emissions	Hospital Laboratories	
9	40-45%	>90%	Welding Fumes		
8	30-35%	>90%	3.0-10.0 pm Particle Size	Commercial Buildings	<b>Pleated Filters</b> - Disposable, extended surface area, thick with cotton-polyester blend media, cardboard frame <b>Cartridge Filters</b> - Graded density viscous coated cube or pocket filters, synthetic media <b>Throwaway</b> - Disposable synthetic panel filter.
7	25-30%	>90%	Mold Spores Hair Spray	Better Residential	
6	<20%	85-90%	Fabric Protector Dusting Aids	Industrial Workplace	
5	<20%	80-85%	Cement Dust Pudding Mix	Paint Booth Inlet	
4	<20%	75-80%	>10.0 pm Particle Size	Minimal Filtration	
3	<20%	70-75%	Pollen	Residential	<b>Washable</b> - Aluminum Mesh <b>Electrostatic</b> - Self charging woven panel filter.
2	<20%	65-70%	Dust Mites Sanding Dust Spray Paint Dust		
1	<20%	<65%	Textile Fibers Carpet Fibers		

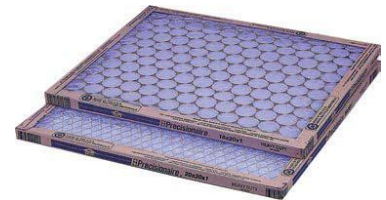



# FIBERGLASS DISPOSABLE FILTERS

Continuous filament spun glass, box frame EZ Flow disposable filters are designed for protection of furnace and central air units in residential and light commercial applications. The EZ Flow features a metal media retainer on the downstream side.



Brauer P/N	Nominal Size	Exact Size	cfm @ 300 fpm	Carton Qty	Weight Per Carton
605018141	8" X 14" X 1"	7-5/8 x 13-5/8 x 3/4	233	12	3.756
605018161	8" X 16" X 1"	7-5/8 x 15-5/8 x 3/4	267	12	3.252
605018201	8" X 20" X 1"	7-5/8 x 19-5/8 x 3/4	333	12	4.752
605018241	8" X 24" X 1"	7-5/8 x 23-5/8 x 3/4	400	12	5.496
605018301	8" X 30" X 1"	7-5/8 x 29-5/8 x 3/4	500	12	2.952
605018361	8" X 36" X 1"	7-5/8 x 35-5/8 x 3/4	600	12	5.472
605011087	10" X 10" X 1"	9-5/8 x 9-5/8 x 3/4	208	12	2.616
6050110161	10" X 16" X 1"	9-5/8 x 15-5/8 x 3/4	333	12	3.192
605011090	10" X 20" X 1"	9-5/8 x 19-5/8 x 3/4	417	12	4.02
605011093	10" X 24" X 1"	9-5/8 x 23-5/8 x 3/4	500	12	4.932
605011095	10" X 25" X 1"	9-5/8 x 24-5/8 x 3/4	521	12	4.752
605011101	10" X 30" X 1"	9-5/8 x 29-5/8 x 3/4	625	12	6.36
605011112	12" X 12" X 1"	11-5/8 x 11-5/8 x 3/4	300	12	3.204
6050112151	12" X 15" X 1"	11-5/8 x 14-5/8 x 3/4	375	12	3.9
6050112161	12" X 16" X 1"	11-5/8 x 15-5/8 x 3/4	400	12	4.032
605011116	12" X 18" X 1"	11-5/8 x 17-5/8 x 3/4	450	12	4.524
605011117	12" X 20" X 1"	11-5/8 x 19-5/8 x 3/4	500	12	4.464
605011121	12" X 24" X 1"	11-5/8 x 23-5/8 x 3/4	600	12	5.472
605011123	12" X 25" X 1"	11-5/8 x 24-5/8 x 3/4	625	12	5.472
605011124	12" X 30" X 1"	11-5/8 x 29-5/8 x 3/4	750	12	5.592
6050112306251	12" X 30-5/8" X 1"	11-5/8 x 30-1/2 x 3/4	766	12	6.684
6050112361	12" X 36" X 1"	11-5/8 x 35-5/8 x 3/4	900	12	6.888
605011130	14" X 14" X 1"	13-5/8 x 13-5/8 x 3/4	408	12	3.912
605011136	14" X 16" X 1"	13-5/8 x 15-3/8 x 3/4	467	12	4.2
6050114181	14" X 18" X 1"	13-5/8 x 17-5/8 x 3/4	525	12	4.284
605011143	14" X 20" X 1"	13-5/8 x 19-5/8 x 3/4	583	12	5.148
605011145	14" X 24" X 1"	13-5/8 x 23-5/8 x 3/4	700	12	5.796
605011147	14" X 25" X 1"	13-5/8 x 24-5/8 x 3/4	729	12	5.34
605011149	14" X 30" X 1"	13-5/8 x 29-5/8 x 3/4	875	12	7.164
6050115161	15" X 16" X 1"	14-5/8 x 15-5/8 x 3/4	500	12	4.3
6050115191	15" X 19" X 1"	14-5/8 x 18-5/8 x 3/4	594	12	4.8
605011167	15" X 20" X 1"	14-5/8 x 19-5/8 x 3/4	625	12	5.616
6050115241	15" X 24" X 1"	14-5/8 x 23-5/8 x 3/4	750	12	6.024
605011169	15" X 25" X 1"	14-5/8 x 24-5/8 x 3/4	781	12	6.024
6050115301	15" X 30" X 1"	14-5/8 x 29-5/8 x 3/4	937	12	7.56
605011171	15" X 30-5/8" X 1"	14-5/8 x 30-1/2 x 3/4	957	12	7.32
6050115351	15" X 35" X 1"	14-5/8 x 34-5/8 x 3/4	1094	12	8.52
605011187	16" X 16" X 1"	15-5/8 x 15-5/8 x 3/4	533	12	4.956
6050116181	16" X 18" X 1"	15-5/8 x 17-5/8 x 3/4	600	12	4.7
605011190	16" X 20" X 1"	15-1/2 x 19-1/2 x 3/4	667	12	5.28
605011201	16" X 22-1/4" X 1"	15-5/8 x 21-1/8 x 3/4	742	12	6.276
605011203	16" X 24" X 1"	15-5/8 x 23-5/8 x 3/4	800	12	5.856
605011220	16" X 25" X 1"	15-5/8 x 24-5/8 x 3/4	833	12	6.24
605011221	16 X 30 X 1	15-5/8 x 29-5/8 x 3/4	1000	12	7.416
6050116321	16" X 32" X 1"	15-5/8 x 31-5/8 x 3/4	1067	12	9
6050117171	17" X 17" X 1"	16-5/8 x 16-5/8 x 3/4	602	12	5.4
6050117191	17" X 19" X 1"	16-5/8 x 18-5/8 x 3/4	673	12	5.4
6050117211	17" X 21" X 1"	16-5/8 x 20-5/8 x 3/4	744	12	6.876
605011222	18" X 18" X 1"	17-5/8 x 17-5/8 x 3/4	675	12	5.388
605011224	18" X 20" X 1"	17-5/8 X 19-5/8 X 3/4	750	12	5.976
605011226	18" X 24" X 1"	17-5/8 x 23-5/8 x 3/4	900	12	6.9
605011241	18" X 25" X 1"	17-5/8 x 24-5/8 x 3/4	937	12	6.072



Brauer P/N	Nominal Size	Exact Size	cfm @ 300 fpm	Carton Qty	Weight Per Carton
6050118301	18" X 30" X 1"	17-5/8 x 29-5/8 x 3/4	1125	12	7.476
6050118361	18" X 36" X 1"	17-5/8 x 35-5/8 x 3/4	1350	12	10.344
6050119211	19" X 21" X 1"	18-5/8 x 20-5/8 x 3/4	831	12	6.2
6050119221	19" X 22" X 1"	18-5/8 x 21-5/8 x 3/4	871	12	6.3
605011255	19" X 27" X 1"	18-5/8 x 26-5/8 x 3/4	1069	12	8.28
605011260	20" X 20" X 1"	19-1/2 x 19-1/2 x 3/4	833	12	6.168
6050120221	20" X 22" X 1"	19-5/8 x 21-5/8 x 3/4	917	12	9.252
605011271	20" X 22-1/4" X 1"	19-7/8 x 22-1/8 x 3/4	927	12	7.344
605011273	20" X 24" X 1"	19-5/8 x 23-5/8 x 3/4	1000	12	7.212
605011280	20" X 25" X 1"	19-1/2 x 24-1/2 x 3/4	1042	12	7.752
605011420	20" x 30" x 1"	19-5/8 x 29-5/8 x 3/4	1250	12	8.868
6050120361	20" X 36" X 1"	19-5/8 x 35-5/8 x 3/4	1500	12	9.996
6050121211	21" X 21" X 1"	20-5/8 x 20-5/8 x 3/4	919	12	6.936
605011349	22" X 22" X 1"	21-5/8 x 21-5/8 x 3/4	1008	12	7.692
605011370	24" X 24" X 1"	23-5/8 x 23-5/8 x 3/4	1200	12	8.712
605011424	24" x 30" x 1"	23-5/8 x 29-5/8 x 3/4	1500	12	11.352
6050124361	24" X 36" X 1"	23-5/8 x 35-5/8 x 3/4	1800	12	11.664
605011401	25" X 25" X 1"	24-5/8 x 24-5/8 x 3/4	1302	12	9.036
6050125301	25" X 30" X 1"	24-5/8 x 29-5/8 x 3/4	1562	12	12
605012087	10" X 10" X 2"	9-5/8 x 9-5/8 x 1-5/8	208	12	3.528
605012090	10" X 20" X 2"	9-5/8 x 19-5/8 x 1-5/8	417	12	5.604
605012121	12" X 24" X 2"	11-1/2 x 23-1/2 x 1-5/8	600	12	6.996
6050112252	12" X 25" X 2"	11-5/8 x 24-5/8 x 1-5/8	625	12	13
605012123	14" X 20" X 2"	13-5/8 x 19-5/8 x 1-5/8	583	12	7.164
605012124	14" X 25" X 2"	13-5/8 x 24-5/8 x 1-5/8	729	12	8.52
605012167	15" X 20" X 2"	14-5/8 x 19-5/8 x 1-5/8	625	12	7.404
605012168	16" X 16" X 2"	15-5/8 x 15-5/8 x 1-5/8	533	12	7.68
605012190	16" X 20" X 2"	15-5/8 x 19-1/2 x 1-5/8	667	12	7.68
605012192	16" X 24" X 2"	15-5/8 x 23-1/2 x 1-5/8	800	12	8.796
605012220	16" X 25" X 2"	15-5/8 x 24-1/2 x 1-5/8	833	12	8.604
6050116302	16" X 30" X 2"	15-5/8 x 29-5/8 x 1-5/8	1000	12	13.87
605012221	18" X 18" X 2"	17-5/8 x 17-5/8 x 1-5/8	675	12	13.45
605012224	18" X 20" X 2"	17-5/8 x 19-5/8 x 1-5/8	750	12	13.55
605012222	18" X 24" X 2"	17-5/8 x 23-5/8 x 1-5/8	900	12	9.696
605012245	18" X 25" X 2"	17-5/8 x 24-5/8 x 1-5/8	937	12	14
605012260	20" X 20" X 2"	19-1/2 x 19-1/2 x 1-5/8	833	12	8.436
605012277	20" X 24" X 2"	19-1/2 x 23-1/2 x 1-5/8	1000	12	10.164
605012280	20" X 25" X 2"	19-1/2 x 24-1/2 x 1-5/8	1042	12	10.596
605012420	20" x 30" x 2"	19-5/8 x 29-5/8 x 1-5/8	1250	12	14.3
605012370	24" X 24" X 2"	23-1/2 x 23-1/2 x 1-5/8	1200	12	11.172
605012401	25" X 25" X 2"	24-5/8 x 24-5/8 x 1-5/8	1302	12	12.204
605011005	FOR AIR HANDLER EBP/EBX 18-24	13-1/16"X21-9/16"X1"	587	12	4.6
	13-1/16"X21-9/16"X1"				
605011010	FOR AIR HANDLER EBP/EBX 30-36	16-3/8"X21-1/2 X1"	733	12	7
	16-3/8"X21-1/2 X1"				
605011015	FOR AIR HANDLER EBP 42-6 / EBX 48	19-15/16"X21-5/16"X1"	885	12	9.252
	19-15/16"X21-5/16"X1"				
605011020	FOR AIR HANDLER EBX 60	21-1/2"X23-7/16 X1"	1050	12	8
	21-1/2"X23-7/16 X1"				



Also available in polyester material and special sizes.



# F312 PINCH FRAME FIBERGLASS DISPOSABLE FILTERS

\* Initial Resistance

1" - 0.07" W.G.

2" - 0.09" W.G.

\* Final Resistance

1" - 0.50" W.G.

2" - 1.00" W.G.

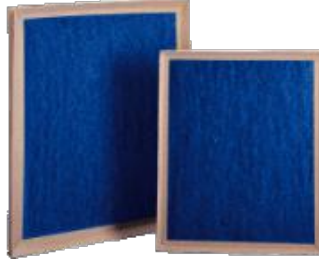

\* Average Arrestance

1" - 70-75%

2" - 70-75%

\* Rated Velocity: 300 FPM

Brauer P/N	AG P/N	Nominal Size	Exact Size	Carton Qty
6053118161	F312-SP	8" X 16" X 1"	7-15/16 x 15-7/8 x 7/8	12
6053118301	F312-155	8" X 30" X 1"	7-15/16 x 29-7/8 x 7/8	12
605311087	F312-109	10" X 10" X 1"	9-7/8 x 9-7/8 x 7/8	12
6053110161	F312-107	10" X 16" X 1"	9-7/8 x 15-7/8 x 7/8	12
605311090	F312-117	10" X 20" X 1"	9-7/8 x 19-5/8 x 7/8	12
605311093	F312-124	10" X 24" X 1"	9-7/8 x 23-3/4 x 7/8	12
605311095	F312-SP	10" X 25" X 1"	9-7/8 x 24-5/8 x 7/8	12
605311101	F312-121	10" X 30" X 1"	9-7/8 x 29-7/8 x 7/8	12
605311112	F312-122	12" X 12" X 1"	11-7/8 x 11-7/8 x 7/8	12
6053112161	F312-123	12" X 16" X 1"	11-7/8 x 15-7/8 x 7/8	12
605311116	F312-126	12" X 18" X 1"	11-7/8 x 17-7/8 x 7/8	12
605311117	F312-120	12" X 20" X 1"	11-7/8 x 19-5/8 x 7/8	12
605311121	F312-110	12" X 24" X 1"	11-7/8 x 23-3/4 x 7/8	12
605311123	F312-113	12" X 25" X 1"	11-7/8 x 24-5/8 x 7/8	12
605311124	F312-154	12" X 30" X 1"	11-7/8 x 29-7/8 x 7/8	12
605311130	F312-133	14" X 14" X 1"	13-7/8 x 13-7/8 x 7/8	12
605311136	F312-SP	14" X 16" X 1"	13-7/8 x 15-7/8 x 7/8	12
6053114181	F312-SP	14" X 18" X 1"	13-7/8 x 17-7/8 x 7/8	12
605311143	F312-139	14" X 20" X 1"	13-7/8 x 19-5/8 x 7/8	12
605311145	F312-136	14" X 24" X 1"	13-7/8 x 23-3/7 x 7/8	12
605311147	F312-141	14" X 25" X 1"	13-7/8 x 24-5/8 x 7/8	12
605311149	F312-137	14" X 30" X 1"	13-7/8 x 29-7/8 x 7/8	12
605311167	F312-145	15" X 20" X 1"	14-7/8 x 19-5/8 x 7/8	12
605311169	F312-STD1	15" x 25" x 1"	14-7/8 x 24-5/8 x 7/8	12
6053115301	F312-140	15" X 30" X 1"	14-7/8 x 29-7/8 x 7/8	12
605311171	F312-135	15" x 30-5/8" x 1"	14-7/8 x 30-5/8 x 7/8	12
605311187	F312-143	16" X 16" X 1"	15-7/8 x 15-7/8 x 7/8	12
605311190	F312-101	16" X 20" X 1"	15-7/8 x 19-5/8 x 7/8	12
605311203	F312-116	16" X 24" X 1"	15-7/8 x 23-3/4 x 7/8	12
605311220	F312-102	16" X 25" X 1"	15-7/8 x 24-5/8 x 7/8	12
605311221	F312-146	16" X 30" X 1"	15-7/8 x 29-7/8 x 7/8	12
605311222	F312-156	18" X 18" X 1"	17-7/8 x 17-7/8 x 7/8	12
605311224	F312-180	18" X 20" X 1"	17-7/8 x 19-5/8 x 7/8	12
605311226	F312-112	18" X 24" X 1"	17-7/8 x 23-3/4 x 7/8	12
605311241	F312-185	18" X 25" X 1"	17-7/8 x 24-5/8 x 7/8	12
6053118301	F312-147	18" X 30" X 1"	17-7/8 x 29-7/8 x 7/8	12
605311260	F312-103	20" X 20" X 1"	19-5/8 x 19-5/8 x 7/8	12
605311271	F312-149	20" X 22-1/4" X 1"	19-5/8 x 22-1/4 x 7/8	12
605311273	F312-111	20" X 24" X 1"	19-5/8 x 23-3/4 x 7/8	12
605311280	F312-104	20" X 25" X 1"	19-5/8 x 24-5/8 x 7/8	12
605311420	F312-132	20" X 30" X 1"	19-5/8 x 29-7/8 x 7/8	12
605311349	F312-151	22" X 22" X 1"	21-15/16 x 21-15/16-7/8	12
605311370	F312-105	24" X 24" X 1"	23-3/4 x 23-3/4 x 7/8	12
605311424	F312-153	24" X 30" X 1"	23-3/4 x 29-7/8 x 7/8	12
605311401	F312-125	25" X 25" X 1"	24-5/8 x 24-5/8 x 7/8	12
605312090	2F-217	10" X 20" X 2"	9-5/8 x 19-5/8 x 1-3/4	12
605312121	2F-210	12" X 24" X 2"	11-3/8 x 23-3/8 x 1-3/4	12
605312123	3F-239	14" X 20" X 2"	13-5/8 x 19-5/8 x 1-3/4	12
605312124	2F-241	14" X 25" X 2"	13-5/8 x 24-5/8 x 1-3/4	12
605312167	2F-245	15" X 20" X 2"	14-5/8 x 19-5/8 x 1-3/4	12
605312168	2F-243	16" X 16" X 2"	15-5/8 x 15-5/8 x 1-3/4	12
605312190	2F-201	16" X 20" X 2"	15-5/8 x 19-5/8 x 1-3/4	12



Brauer P/N	AG P/N	Nominal Size	Exact Size	Carton Qty
605312192	2F-216	16" X 24" X 2"	15-5/8 x 23-5/8 x 1-3/4	12
605312220	2F-202	16" X 25" X 2"	15-5/8 x 24-5/8 x 1-3/4	12
605312222	2F-212	18" X 24" X 2"	17-5/8 x 23-5/8 x 1-3/4	12
605312260	2F-203	20" X 20" X 2"	19-5/8 x 19-5/8 x 1-3/4	12
605312277	2F-211	20" X 24" X 2"	19-5/8 x 23-5/8 x 1-3/4	12
605312280	2F-204	20" X 25" X 2"	19-5/8 x 24-5/8 x 1-3/4	12
605312370	2F-205	24" X 24" X 2"	23-3/8 x 23-3/8 x 1-3/4	12
605312401	2F-225	25" X 25" X 2"	24-3/8 x 24-3/8 x 1-3/4	12



Also available in polyester material and special sizes.

## MX40 STANDARD CAPACITY PLEATED FILTER MERV 8

Heavy duty beverage board frame, 100% synthetic media, media pack support member, galvanized steel pleat support grid, water repellent adhesive and double wall frame.

1" = 12.0 pleats per foot

2" = 10.0 pleats per foot

4" = 9.0 pleats per foot

6" = 9.0 pleats per foot



Brauer P/N	AG P/N	Nominal Size	Exact Size	Carton Qty	Rated Air Flow CFM	Initial Resistance	Media Area
607010960	MX40-109	10 X 10 X 1	9-1/2 X 9-1/2 X 3/4	12	210	0.21	1.5
607010970	MX40-117	10 X 20 X 1	9-1/2 x 19-1/2 x 3/4	12	415	0.21	2.4
607010973	MX40-124	10 X 24 X 1	9-3/8 x 23-3/8 x 3/4	12	500	0.21	2.9
607010975	MX40-122	12 X 12 X 1	11-3/4 x 11-3/4 x 3/4	12	300	0.21	1.8
607010977	MX40-123	12 X 16 X 1	11-1/2 x 15-3/4 x 3/4	12	400	0.21	2.3
607010980	MX40-120	12 X 20 X 1	11-1/2 x 19-1/2 x 3/4	12	500	0.21	2.9
607010990	MX40-110	12 X 24 X 1	11-3/8 x 23-3/8 x 3/4	12	600	0.21	3.4
607011414	MX40-133	14 X 14 X 1	13-3/4 x 13-3/4 x 3/4	12	410	0.21	2.4
607011000	MX40-139	14 X 20 X 1	13-1/2 x 19-1/2 x 3/4	12	585	0.21	3.4
607011002	MX40-159	14 X 24 X 1	13-3/8 x 23-3/8 x 3/4	12	700	0.21	4
607011105	MX40-141	14 X 25 X 1	13-1/2 x 24-1/2 x 3/4	12	730	0.21	4.2
607011107	MX40-137	14 X 30 X 1	13-3/4 x 29-3/4 x 3/4	12	875	0.21	5
607011110	MX40-145	15 X 20 X 1	14-1/2 x 19-1/2 x 3/4	12	625	0.21	3.6
607011115	MX40-143	16 X 16 X 1	15-1/2 x 15-1/2 x 3/4	12	530	0.21	3.1
607011120	MX40-101	16 X 20 X 1	15-1/2 x 19-1/2 x 3/4	12	665	0.21	3.8
607011124	MX40-116	16 X 24 X 1	15-3/8 x 23-3/8 x 3/4	12	800	0.21	4.6
607011130	MX40-102	16 X 25 X 1	15-1/2 x 24-1/2 x 3/4	12	835	0.21	4.8
607011132	MX40-146	16 X 30 X 1	15-3/4 x 29-3/4 x 3/4	12	1000	0.21	5.8
607011818	MX40-163	18 X 18 X 1	17-3/4 x 17-3/4 x 3/4	12	675	0.21	3.7
607011135	MX40-180	18 X 20 X 1	17-3/8 x 19-1/2 x 3/4	12	750	0.21	4
607011137	MX40-182	18 X 22 X 1	17-3/8 x 21-1/2 x 3/4	12	825	0.21	4.8
607011140	MX40-112	18 X 24 X 1	17-3/8 x 23-3/8 x 3/4	12	900	0.21	4.8
607011145	MX40-185	18 X 25 X 1	17-1/2 x 24-1/2 x 3/4	12	935	0.21	5.1
607011150	MX40-103	20 X 20 X 1	19-1/2 x 19-1/2 x 3/4	12	830	0.21	4.8
607011155	MX40-166	20 X 22 X 1	19-3/4 x 21-3/4 x 3/4	12	915	0.21	5.7
607011165	MX40-111	20 X 24 X 1	19-3/8 x 23-3/8 x 3/4	12	1000	0.21	5.7
607011170	MX40-104	20 X 25 X 1	19-1/2 x 24-1/2 x 3/4	12	1040	0.21	6
607011175	MX40-132	30 X 20 X 1	29-1/2 x 19-1/2 x 3/4	12	1250	0.21	7.2
607011195	MX40-151	22 X 22 X 1	21-3/4 x 21-3/4 x 3/4	12	1005	0.21	5
607011180	MX40-105	24 X 24 X 1	23-3/8 x 23-3/8 x 3/4	12	1200	0.21	6.6
607011185	MX40-153	24 X 30 X 1	23-3/4 x 29-3/4 x 3/4	12	1500	0.21	8.5
607011190	MX40-125	25 X 25 X 1	24-1/2 x 24-1/2 x 3/4	12	1300	0.21	7.5
607012110	XL8-SC	10 X 20 X 2	9-1/2 x 19-1/2 x 1-3/4	12	700	0.28	4.1
607012117	MX40-222	12 X 12 X 2	11-3/4 x 11-3/4 x 1-3/4	12	500	0.22	3.1



Brauer P/N	AG P/N	Nominal Size	Exact Size	Carton Qty	Rated Air Flow CFM	Initial Resistance	Media Area
607012115	MX40-220	12 X 20 X 2	11-1/2 x 19-1/2 x 1-3/4	12	830	0.22	5.2
607012120	MX40-210	12 X 24 X 2	11-3/8 x 23-3/8 x 1-3/4	12	1000	0.22	6.2
607012130	MX40-239	14 X 20 X 2	13-1/2 x 19-1/2 x 1-3/4	12	980	0.22	5.7
607012140	MX40-241	14 X 25 X 2	13-1/2 x 24-1/2 x 1-3/4	12	1220	0.22	7.1
607012160	MX40-245	15 X 20 X 2	14-1/2 x 19-1/2 x 1-3/4	12	1050	0.22	6.2
607012175	MX40-243	16 X 16 X 2	15-3/4 x 15-3/4 x 1-3/4	12	890	0.22	6.7
607012190	MX40-201	16 X 20 X 2	15-1/2 x 19-1/2 x 1-3/4	12	1110	0.22	6.7
607012215	MX40-216	16 X 24 X 2	15-3/8 x 23-3/8 x 1-3/4	12	1330	0.22	8
607012220	MX40-202	16 X 25 X 2	15-1/2 x 24-1/2 x 1-3/4	12	1400	0.22	8
607012222	MX40-263	18 X 18 X 2	17-3/4 x 17-3/4 x 1-3/4	12	1125	0.22	7
607012225	MX40-280	18 X 20 X 2	17-1/2 x 19-1/2 x 1-3/4	12	1250	0.22	7.7
607012227	MX40-282	18 X 22 X 2	17-1/2 x 21-1/2 x 1-3/4	12	1375	0.22	9.3
607012240	MX40-212	18 X 24 X 2	17-3/8 x 23-3/8 x 1-3/4	12	1500	0.22	9.3
607012245	MX40-285	18 X 25 X 2	17-1/2 x 24-1/2 x 1-3/4	12	1560	0.22	9.7
607012260	MX40-203	20 X 20 X 2	19-1/2 x 19-1/2 x 1-3/4	12	1400	0.22	8.3
607012270	MX40-211	20 X 24 X 2	19-3/8 x 23-3/8 x 1-3/4	12	1670	0.22	9.9
607012280	MX40-204	20 X 25 X 2	19-1/2 x 24-1/2 x 1-3/4	12	1730	0.22	10.3
607012285	MX40-232	30 X 20 X 2	19-1/2 x 29-1/2 x 1-3/4	12	2080	0.22	12.9
607012370	MX40-205	24 X 24 X 2	23-3/8 x 23-3/8 x 1-3/4	12	2000	0.22	11.7
607012380	MX40-225	25 X 25 X 2	24-1/2 x 24-1/2 x 1-3/4	12	2170	0.22	12.9
607014170	MX40-410	12 X 24 X 4	11-3/8 x 23-3/8 x 3-3/4	6	1000	0.19	11.2
607014190	MX40-401	16 X 20 X 4	15-1/2 x 19-1/2 x 3-3/4	6	1110	0.19	12.5
607014220	MX40-402	16 X 25 X 4	15-1/2 x 24-1/2 x 3-3/4	6	1400	0.19	15.6
607014238	MX40-412	18 X 24 X 4	17-3/8 x 23-3/8 x 3-3/4	6	1500	0.19	16.2
607014260	MX40-403	20 X 20 X 4	19-1/2 x 19-1/2 x 3-3/4	6	1400	0.19	15.6
607014270	MX40-411	20 X 24 X 4	19-3/8 x 23-3/8 x 3-3/4	6	1670	0.19	18.7
607014280	MX40-404	20 X 25 X 4	19-1/2 x 24-1/2 x 3-3/4	6	1730	0.19	19.6
607014370	MX40-405	24 X 24 X 4	23-3/8 x 23-3/8 x 3-3/4	6	2000	0.19	22.4
607016120	MX40-610	12 X 24 X 6	11-3/8 x 23-3/8 x 5-7/8	4	1000	0.18	16.9
607016190	MX40-601	16 X 20 X 6	15-1/2 x 19-1/2 x 5-7/8	2	1110	0.18	18.9
607016220	MX40-602	16 X 25 X 6	15-1/2 x 24-1/2 x 5-7/8	2	1400	0.18	23.6
607016240	MX40-612	18 X 24 X 6	17-3/8 x 23-3/8 x 5-7/8	2	1500	0.18	26.3
607016260	MX40-603	20 X 20 X 6	19-1/2 x 19-1/2 x 5-7/8	2	1400	0.18	23.7
607016270	MX40-611	20 X 24 X 6	19-3/8 x 23-3/8 x 5-7/8	2	1670	0.18	28.2
607016280	MX40-604	20 X 25 X 6	19-1/2 x 24-1/2 x 5-7/8	2	1730	0.18	29.5
607016370	MX40-605	24 X 24 X 6	23-3/8 x 23-3/8 x 5-7/8	2	2000	0.18	33.8

Brauer P/N	AG P/N	Nominal Size	Exact Size	Carton Qty
Special Sizes				
607012428	MX40-1SP	23-3/4 X 27-3/4 X 1	23-3/4 X 27-3/4 X 1	12
6070128301	MX40-1SP	27-3/4 X 29-3/4 X 1	27-3/4 X 29-3/4 X 1	12
607013036	MX40-1SP	29-3/4 X 35-3/4 X 1	29-3/4 X 35-3/4 X 1	12
607012830	MX40-2SP	27-3/4 X 29-3/4 X 2	27-3/4 X 29-3/4 X 2	12
607013032	MX40-2SP	29-3/4 X 31-3/4 X 2	29-3/4 X 31-3/4 X 2	12
6070130362	MX40-2SP	29-3/4 X 35-3/4 X 2	29-3/4 X 35-3/4 X 2	12
607011321	MX40-1SP	13 X 21-1/2 X 1	13 X 21-1/2 X 1	12
607011621	MX40-1SP	16-3/8 X 21-1/2 X 1	16-3/8 X 21-1/2 X 1	12
607011921	MX40-1SP	19-7/8 X 21-1/4 X 1	19-7/8 X 21-1/4 X 1	12
607012123	MX40-1SP	21-1/2 X 23-3/8 X 1	21-1/2 X 23-3/8 X 1	12

Also available in special sizes.





# DP40 HIGH CAPACITY PLEATED FILTER MERV 8



Heavy duty beverage board frame, 100% synthetic media, media pack support member, galvanized steel pleat support grid, water repellent adhesive and double wall frame.

1" = 14.0 pleats per foot

4" = 11.0 pleats per foot

2" = 15.0 pleats per foot

Brauer P/N	AG P/N	Nominal Size	Exact Size	Carton Qty	Rated Air Flow CFM	Initial Resistance	Media Area
607110960	DP40-109	10 X 10 X 1	9-1/2 X 9-1/2 X 3/4	12	208	0.16	1.6
607110970	DP40-117	10 X 20 X 1	9-1/2 x 19-1/2 x 3/4	12	425	0.16	2.6
607110973	DP40-124	10 X 24 X 1	9-3/8 x 23-3/8 x 3/4	12	500	0.16	3.1
607110975	DP40-122	12 X 12 X 1	11-3/4 x 11-3/4 x 3/4	12	300	0.16	1.9
607110977	DP40-123	12 X 16 X 1	11-1/2 x 15-3/4 x 3/4	12	400	0.16	2.5
607110980	DP40-120	12 X 20 X 1	11-1/2 x 19-1/2 x 3/4	12	500	0.16	3.1
607110990	DP40-110	12 X 24 X 1	11-3/8 x 23-3/8 x 3/4	12	600	0.16	3.7
607111414	DP40-133	14 X 14 X 1	13-3/4 x 13-3/4 x 3/4	12	408	0.16	2.7
607111000	DP40-139	14 X 20 X 1	13-1/2 x 19-1/2 x 3/4	12	590	0.16	3.8
607111002	DP40-159	14 X 24 X 1	13-3/8 x 23-3/8 x 3/4	12	700	0.16	4.6
607111105	DP40-141	14 X 25 X 1	13-1/2 x 24-1/2 x 3/4	12	730	0.16	4.8
607111107	DP40-137	14 X 30 X 1	13-3/4 x 29-3/4 x 3/4	12	875	0.16	5.7
607111110	DP40-145	15 X 20 X 1	14-1/2 x 19-1/2 x 3/4	12	630	0.16	4.1
607111530	DP40-140	15 X 30 X 1	14-3/4 x 29-3/4 x 3/4	12	938	0.16	6.1
607111115	DP40-143	16 X 16 X 1	15-1/2 x 15-1/2 x 3/4	12	533	0.16	4.0
607111120	DP40-101	16 X 20 X 1	15-1/2 x 19-1/2 x 3/4	12	670	0.16	4.3
607111124	DP40-116	16 X 24 X 1	15-3/8 x 23-3/8 x 3/4	12	800	0.16	5.1
607111130	DP40-102	16 X 25 X 1	15-1/2 x 24-1/2 x 3/4	12	840	0.16	5.4
607111132	DP40-146	16 X 30 X 1	15-3/4 x 29-3/4 x 3/4	12	1000	0.16	6.5
607111818	DP40-163	18 X 18 X 1	17-3/4 x 17-3/4 x 3/4	12	675	0.16	4.3
607111135	DP40-180	18 X 20 X 1	17-3/8 x 19-1/2 x 3/4	12	750	0.16	4.8
607111137	DP40-182	18 X 22 X 1	17-3/8 x 21-1/2 x 3/4	12	825	0.16	5.7
607111140	DP40-112	18 X 24 X 1	17-3/8 x 23-3/8 x 3/4	12	900	0.16	5.7
607111145	DP40-185	18 X 25 X 1	17-1/2 x 24-1/2 x 3/4	12	940	0.16	6.0
607111150	DP40-103	20 X 20 X 1	19-1/2 x 19-1/2 x 3/4	12	840	0.16	5.5
607111155	DP40-166	20 X 22 X 1	19-3/4 x 21-3/4 x 3/4	12	917	0.16	6.6
607111165	DP40-111	20 X 24 X 1	19-3/8 x 23-3/8 x 3/4	12	1000	0.16	6.6
607111170	DP40-104	20 X 25 X 1	19-1/2 x 24-1/2 x 3/4	12	1050	0.16	6.9
607111175	DP40-132	20 X 30 X 1	20-1/2 x 19-1/2 x 3/4	12	1250	0.16	8.2
607111195	DP40-151	22 X 22 X 1	21-3/4 x 21-3/4 x 3/4	12	1008	0.16	7.1
607111180	DP40-105	24 X 24 X 1	23-3/8 x 23-3/8 x 3/4	12	1200	0.16	7.7
607111185	DP40-153	24 X 30 X 1	23-3/4 x 29-3/4 x 3/4	12	1500	0.16	9.7
607111190	DP40-125	25 X 25 X 1	24-1/2 x 24-1/2 x 3/4	12	1310	0.16	8.7
607112110	DP40-217	10 X 20 X 2	9-1/2 x 19-1/2 x 1-3/4	12	700	0.21	5.7
607112117	DP40-222	12 X 12 X 2	11-3/4 x 11-3/4 x 1-3/4	12	500	0.21	3.1
607112115	DP40-220	12 X 20 X 2	11-1/2 x 19-1/2 x 1-3/4	12	840	0.21	7.3
607112120	DP40-210	12 X 24 X 2	11-3/8 x 23-3/8 x 1-3/4	12	1000	0.21	8.6
607112130	DP40-239	14 X 20 X 2	13-1/2 x 19-1/2 x 1-3/4	12	980	0.21	8.8
607112140	DP40-241	14 X 25 X 2	13-1/2 x 24-1/2 x 1-3/4	12	1220	0.21	11.0
607112160	DP40-245	15 X 20 X 2	14-1/2 x 19-1/2 x 1-3/4	12	1050	0.21	9.3
607112175	DP40-243	16 X 16 X 2	15-3/4 x 15-3/4 x 1-3/4	12	888	0.21	6.7
607112190	DP40-201	16 X 20 X 2	15-1/2 x 19-1/2 x 1-3/4	12	1120	0.21	9.9
607112215	DP40-216	16 X 24 X 2	15-3/8 x 23-3/8 x 1-3/4	12	1340	0.21	11.7
607112220	DP40-202	16 X 25 X 2	15-1/2 x 24-1/2 x 1-3/4	12	1400	0.21	12.3
607112222	DP40-263	18 X 18 X 2	17-3/4 x 17-3/4 x 1-3/4	12	1125	0.21	7.0
607112225	DP40-280	18 X 20 X 2	17-1/2 x 19-1/2 x 1-3/4	12	1250	0.21	11.4
607112227	DP40-282	18 X 22 X 2	17-1/2 x 21-1/2 x 1-3/4	12	1375	0.21	9.3
607112240	DP40-212	18 X 24 X 2	17-3/8 x 23-3/8 x 1-3/4	12	1500	0.21	13.6
607112245	DP40-285	18 X 25 X 2	17-1/2 x 24-1/2 x 1-3/4	12	1570	0.21	14.2
607112260	DP40-203	20 X 20 X 2	19-1/2 x 19-1/2 x 1-3/4	12	1400	0.21	12.4
607112270	DP40-211	20 X 24 X 2	19-3/8 x 23-3/8 x 1-3/4	12	1670	0.21	14.8
607112280	DP40-204	20 X 25 X 2	19-1/2 x 24-1/2 x 1-3/4	12	1750	0.21	15.5
607112285	DP40-232	20 X 30 X 2	19-1/2 x 29-1/2 x 1-3/4	12	2083	0.21	12.9
607112370	DP40-205	24 X 24 X 2	23-3/8 x 23-3/8 x 1-3/4	12	2000	0.21	17.9
607112380	DP40-225	25 X 25 X 2	24-1/2 x 24-1/2 x 1-3/4	12	2170	0.21	20.0



Brauer P/N	AG P/N	Nominal Size	Exact Size	Carton Qty	Rated Air Flow CFM	Initial Resistance	Media Area
607114170	DP40-410	12 X 24 X 4	11-3/8 x 23-3/8 x 3-3/4	6	1000	0.18	12.4
607114190	DP40-401	16 X 20 X 4	15-1/2 x 19-1/2 x 3-3/4	6	1120	0.18	14.6
607114220	DP40-402	16 X 25 X 4	15-1/2 x 24-1/2 x 3-3/4	6	1400	0.18	18.3
607114238	DP40-412	18 X 24 X 4	17-3/8 x 23-3/8 x 3-3/4	6	1500	0.18	19.9
607114260	DP40-403	20 X 20 X 4	19-1/2 x 19-1/2 x 3-3/4	6	1400	0.18	18.8
607114270	DP40-411	20 X 24 X 4	19-3/8 x 23-3/8 x 3-3/4	6	1670	0.18	22.4
607114280	DP40-404	20 X 25 X 4	19-1/2 x 24-1/2 x 3-3/4	6	1750	0.18	23.5
607114370	DP40-405	24 X 24 X 4	23-3/8 x 23-3/8 x 3-3/4	6	2000	0.18	27.4
6071125294	DP40-424	24.5 X 28.5 X 4	28-1/2 x 24-1/2 x 3-3/4	3	2430	0.18	32.6
6071128304	DP40-430	28 X 30 X 4	29-1/2 x 27-1/2 x 3-3/4	3	2920	0.18	38.5

Also available in special sizes.

## XP STANDARD CAPACITY PLEATED FILTER MERV 8



100% synthetic, self-supporting media, (3) pleat stabilizer straps, upstream side, media pack support grid, downstream side and moisture resistant beverage board frame.

1" = 12.0 pleats per foot

4" = 11.3 pleats per foot

2" = 10.16 pleats per foot

Brauer P/N	AG P/N	Nominal Size	Exact Size	Carton Qty	Rated Air Flow CFM	Initial Resistance	Media Area
607510970	XP-117	10 X 20 X 1	9-1/2 x 19-1/2 x 3/4	12	415	0.15	2.3
607510973	XP-124	10 X 24 X 1	9-3/8 x 23-3/8 x 3/4	12	500	0.15	2.8
607510975	XP-122	12 X 12 X 1	11-3/4 x 11-3/4 x 3/4	12	300	0.15	1.8
607510980	XP-120	12 X 20 X 1	11-1/2 x 19-1/2 x 3/4	12	500	0.15	2.8
607510990	XP-110	12 X 24 X 1	11-3/8 x 23-3/8 x 3/4	12	600	0.15	3.4
607511414	XP-133	14 X 14 X 1	13-3/4 x 13-3/4 x 3/4	12	410	0.15	2.4
607511000	XP-139	14 X 20 X 1	13-1/2 x 19-1/2 x 3/4	12	585	0.15	3.3
607511002	XP-159	14 X 24 X 1	13-3/8 x 23-3/8 x 3/4	12	700	0.15	4.0
607511105	XP-141	14 X 25 X 1	13-1/2 x 24-1/2 x 3/4	12	730	0.15	4.2
607511107	XP-137	14 X 30 X 1	13-3/4 x 29-3/4 x 3/4	12	875	0.15	5.2
607511110	XP-145	15 X 20 X 1	14-1/2 x 19-1/2 x 3/4	12	625	0.15	3.6
607511115	XP-143	16 X 16 X 1	15-1/2 x 15-1/2 x 3/4	12	530	0.15	3.0
607511120	XP-101	16 X 20 X 1	15-1/2 x 19-1/2 x 3/4	12	665	0.15	3.8
607511124	XP-116	16 X 24 X 1	15-3/8 x 23-3/8 x 3/4	12	800	0.15	4.6
607511130	XP-102	16 X 25 X 1	15-1/2 x 24-1/2 x 3/4	12	835	0.15	4.8
607511132	XP-146	16 X 30 X 1	15-3/4 x 29-3/4 x 3/4	12	1000	0.15	6.0
607511818	XP-163	18 X 18 X 1	17-3/4 x 17-3/4 x 3/4	12	675	0.15	4.1
607511135	XP-180	18 X 20 X 1	17-3/8 x 19-1/2 x 3/4	12	750	0.15	4.3
607511140	XP-112	18 X 24 X 1	17-3/8 x 23-3/8 x 3/4	12	900	0.15	5.2
607511145	XP-185	18 X 25 X 1	17-1/2 x 24-1/2 x 3/4	12	936	0.15	5.4
607511150	XP-103	20 X 20 X 1	19-1/2 x 19-1/2 x 3/4	12	830	0.15	4.8
607511155	XP-166	20 X 22 X 1	19-3/4 x 21-3/4 x 3/4	12	915	0.15	5.5
607511165	XP-111	20 X 24 X 1	19-3/8 x 23-3/8 x 3/4	12	1000	0.15	5.9
607511170	XP-104	20 X 25 X 1	19-1/2 x 24-1/2 x 3/4	12	1040	0.15	6.1
607511175	XP-132	20 X 30 X 1	19-1/2 x 29-1/2 x 3/4	12	1250	0.15	7.3
607511180	XP-105	24 X 24 X 1	23-3/8 x 23-3/8 x 3/4	12	1200	0.15	7.0
607511185	XP-153	24 X 30 X 1	23-3/4 x 29-3/4 x 3/4	12	1500	0.15	9.1
607511190	XP-125	25 X 25 X 1	24-1/2 x 24-1/2 x 3/4	12	1300	0.15	7.7

Brauer P/N	AG P/N	Nominal Size	Exact Size	Carton Qty	Rated Air Flow CFM	Initial Resistance	Media Area
607512110	XP-217	10 X 20 X 2	9-1/2 x 19-1/2 x 1-3/4	12	700	0.22	4.0
607512115	XP-220	12 X 20 X 2	11-1/2 x 19-1/2 x 1-3/4	12	840	0.22	4.8
607512120	XP-210	12 X 24 X 2	11-3/8 x 23-3/8 x 1-3/4	12	1000	0.22	5.7
607512130	XP-239	14 X 20 X 2	13-1/2 x 19-1/2 x 1-3/4	12	980	0.22	5.5
607512140	XP-241	14 X 25 X 2	13-1/2 x 24-1/2 x 1-3/4	12	1220	0.22	6.9
607512160	XP-245	15 X 20 X 2	14-1/2 x 19-1/2 x 1-3/4	12	1050	0.22	6.0
607512175	XP-243	16 X 16 X 2	15-3/4 x 15-3/4 x 1-3/4	12	890	0.22	5.3
607512190	XP-201	16 X 20 X 2	15-1/2 x 19-1/2 x 1-3/4	12	1120	0.22	6.5
607512215	XP-216	16 X 24 X 2	15-3/8 x 23-3/8 x 1-3/4	12	1340	0.22	7.5
607512220	XP-202	16 X 25 X 2	15-1/2 x 24-1/2 x 1-3/4	12	1400	0.22	8.2
607512222	XP-263	18 X 18 X 2	17-3/4 x 17-3/4 x 1-3/4	12	1125	0.22	6.6
607512225	XP-280	18 X 20 X 2	17-1/2 x 19-1/2 x 1-3/4	12	1250	0.22	7.3
607512240	XP-212	18 X 24 X 2	17-3/8 x 23-3/8 x 1-3/4	12	1500	0.22	8.7
607512245	XP-285	18 X 25 X 2	17-1/2 x 24-1/2 x 1-3/4	12	1570	0.22	9.2
607512260	XP-203	20 X 20 X 2	19-1/2 x 19-1/2 x 1-3/4	12	1400	0.22	8.0
607512270	XP-211	20 X 24 X 2	19-3/8 x 23-3/8 x 1-3/4	12	1670	0.22	9.6
607512280	XP-204	20 X 25 X 2	19-1/2 x 24-1/2 x 1-3/4	12	1750	0.22	10.1
607512285	XP-232	20 X 30 X 2	19-1/2 x 29-1/2 x 1-3/4	12	2085	0.22	12.2
607512370	XP-205	24 X 24 X 2	23-3/8 x 23-3/8 x 1-3/4	12	2000	0.22	11.8
607512380	XP-225	25 X 25 X 2	24-1/2 x 24-1/2 x 1-3/4	12	2170	0.22	12.9
Brauer P/N	AG P/N	Nominal Size	Exact Size	Carton Qty	Rated Air Flow CFM	Initial Resistance	Media Area
607514170	XPH-410	12 X 24 X 4	11-3/8 x 23-3/8 x 3-3/4	6	1000	0.15	13.0
607514190	XPH-401	16 X 20 X 4	15-1/2 x 19-1/2 x 3-3/4	6	1120	0.15	14.9
607514220	XPH-402	16 X 25 X 4	15-1/2 x 24-1/2 x 3-3/4	6	1400	0.15	18.8
607514238	XPH-412	18 X 24 X 4	17-3/8 x 23-3/8 x 3-3/4	6	1500	0.15	19.7
607514260	XPH-403	20 X 20 X 4	19-1/2 x 19-1/2 x 3-3/4	6	1400	0.15	18.5
607514270	XPH-411	20 X 24 X 4	19-3/8 x 23-3/8 x 3-3/4	6	1670	0.15	22.2
607514280	XPH-404	20 X 25 X 4	19-1/2 x 24-1/2 x 3-3/4	6	1750	0.15	23.3
607514370	XPH-405	24 X 24 X 4	23-3/8 x 23-3/8 x 3-3/4	6	2000	0.15	26.5

Also available in special sizes.

## PWG HIGH PLEATED FILTER MERV 11

White electrostatic synthetic media, expanded metal pleat supports, moisture resistant beverage board frame and double wall frame.

1" = 14.0 pleats per foot

4" = 11.0 pleats per foot

2" = 15.0 pleats per foot



Brauer P/N	AG P/N	Nominal Size	Exact Size	Carton Qty	Rated Air Flow CFM	Initial Resistance	Media Area
607310970	PWG-117	10 X 20 X 1	19-1/2 X 19-1/2 X 3/4	12	425	0.29	2.6
607310980	PWG-120	12 X 20 X 1	11-1/2 X 19-1/2 X 3/4	12	500	0.29	3.1
607310990	PWG-110	12 X 24 X 1	11-3/8 X 23-3/8 X 3/4	12	600	0.29	3.7
607311000	PWG-139	14 X 20 X 1	13-1/2 X 19-1/2 X 3/4	12	590	0.29	3.8
607311105	PWG-141	14 X 25 X 1	13-1/2 X 24-1/2 X 3/4	12	730	0.29	4.8
607311110	PWG-145	15 X 20 X 1	14-1/2 X 19-1/2 X 3/4	12	630	0.29	4.0
607311120	PWG-101	16 X 20 X 1	15-1/2 X 24-1/2 X 3/4	12	670	0.29	4.3
607311130	PWG-102	16 X 25 X 1	15-1/2 X 24-1/2 X 3/4	12	840	0.29	5.4
607311140	PWG-112	18 X 24 X 1	17-3/8 X 23-3/8 X 3/4	12	900	0.29	5.7
607311150	PWG-103	20 X 20 X 1	19-1/2 X 19-1/2 X 3/4	12	840	0.29	5.5
607311170	PWG-104	20 X 25 X 1	19-1/2 X 24-1/2 X 3/4	12	1050	0.29	6.9
607311180	PWG-105	24 X 24 X 1	23-3/8 X 23-3/8 X 3/4	12	1200	0.29	7.7
607311190	PWG-125	25 X 25 X 1	24-1/2 X 24-1/2 X 3/4	12	1310	0.28	8.7



Brauer P/N	AG P/N	Nominal Size	Exact Size	Carton Qty	Rated Air Flow CFM	Initial Resistance	Media Area
607312110	PWG-217	10 X 20 X 2	9-1/2 X 19-1/2 X 1-3/4	12	700	0.30	6.2
607312115	PWG-220	12 X 20 X 2	11-3/4 X 19-3/4 X 1-3/4	12	840	0.30	7.2
607312120	PWG-210	12 X 24 X 2	11-3/8 X 23-3/8 X 1-3/4	12	1000	0.30	8.6
607312130	PWG-239	14 X 20 X 2	13-3/4 X 19-3/4 X 1-3/4	12	980	0.30	8.8
607312140	PWG-241	14 X 25 X 2	13-3/4 X 24-3/4 X 1-3/4	12	1220	0.30	11.0
607312160	PWG-245	15 X 20 X 2	14-3/4 X 19-3/4 X 1-3/4	12	1050	0.30	9.3
607312190	PWG-201	16 X 20 X 2	15-1/2 X 19-1/2 X 1-3/4	12	1200	0.30	9.8
607312215	PWG-216	16 X 24 X 2	15-1/2 X 23-1/2 X 1-3/4	12	1340	0.30	11.7
607312220	PWG-202	16 X 25 X 2	15-1/2 X 24-3/4 X 1-3/4	12	1400	0.30	12.3
607312225	PWG-280	18 X 20 X 2	17-3/4 X 19-3/4 X 1-3/4	12	1250	0.30	11.3
607312240	PWG-212	18 X 24 X 2	17-1/2 X 23-1/2 X 1-3/4	12	1500	0.30	13.6
607312245	PWG-285	18 X 25 X 2	17-3/4 X 24-3/4 X 1-3/4	12	1570	0.30	14.2
607312260	PWG-203	20 X 20 X 2	19-1/2 X 19-1/2 X 1-3/4	12	1400	0.30	12.4
607312270	PWG-211	20 X 24 X 2	19-3/8 X 23-3/8 X 1-3/4	12	1670	0.30	14.8
607312280	PWG-204	20 X 25 X 2	19-1/2 X 24-1/2 X 1-3/4	12	1750	0.30	15.1
607312285	PWG-232	20 X 30 X 2	19-1/2 X 29-1/2 X 1-3/4	12	2080	0.30	18.6
607312370	PWG-205	24 X 24 X 2	23-3/8 X 23-3/8 X 1-3/4	12	2000	0.30	17.9
607312380	PWG-225	25 X 25 X 2	24-3/4 X 24-3/4 X 1-3/4	12	2170	0.30	20.0
Brauer P/N	AG P/N	Nominal Size	Exact Size	Carton Qty	Rated Air Flow CFM	Initial Resistance	Media Area
607314170	PWG-410	12 X 24 X 4	11-3/8 x 23-3/8 x 3-3/4	6	1000	0.25	12.4
607314172	PWG-SP	14 X 20 X 4	13-1/2 x 19-1/2 x 3-3/4	6		0.25	
607314190	PWG-401	16 X 20 X 4	15-1/2 x 19-1/2 x 3-3/4	6	1200	0.25	14.5
607314220	PWG-402	16 X 25 X 4	15-1/2 x 24-3/4 x 3-3/4	6	1400	0.25	18.3
607314238	PWG-412	18 X 24 X 4	17-1/2 x 23-1/2 x 3-3/4	6	1500	0.25	19.9
607314260	PWG-403	20 X 20 X 4	19-1/2 x 19-1/2 x 3-3/4	6	1400	0.25	18.7
607314270	PWG-411	20 X 24 X 4	19-3/8 x 23-3/8 x 3-3/4	6	1670	0.25	22.4
607314280	PWG-404	20 X 25 X 4	19-1/2 x 24-1/2 x 3-3/4	6	1750	0.25	23.5
607314370	PWG-405	24 X 24 X 4	23-3/8 x 23-3/8 x 3-3/4	6	2000	0.25	27.4
607314385	PWG-428	25 X 29 X 4	24-1/2 x 28-1/2 x 3-3/4	6	2500	0.25	36.5

Brauer P/N	AG P/N	Nominal Size	Exact Size	Carton Qty
607313230	PWG-SP	30 X 32 X 1	29-3/4 x 31-3/4 x 3/4	12
607313630	PWG-SP	30 X 36 X 1	29-3/4 x 35-3/4 x 3/4	12
607312830	PWG-SP	28 X 30 X 2	27-3/4 x 29-3/4 x 1-3/4	12
607313032	PWG-SP	30 X 32 X 2	29-3/4 x 31-3/4 x 1-3/4	12
607313036	PWG-SP	30 X 36 X 2	29-3/4 x 35-3/4 x 1-3/4	12

Also available in special sizes.



## DP13 HIGH PLEATED FILTER MERV 13

100% synthetic white media, expanded metal pleat supports, moisture resistant beverage board frame and double wall frame.

1" = 17.0 pleats per foot

4" = 11.0 pleats per foot

2" = 15.5 pleats per foot



Brauer P/N	AG P/N	Nominal Size	Exact Size	Carton Qty	Rated Air Flow CFM	Initial Resistance	Media Area
607130960	DP13-109	10 X 10 X 1	9-1/2 X 9-1/2 X 3/4	12	210	0.41	1.9
607130961	DP13-177	10 X 15 X 1	9-3/4 X 14-3/4 X 3/4	12	310	0.41	3.1
607130970	DP13-117	10 X 20 X 1	9-1/2 X 19-1/2 X 3/4	12	415	0.41	3.1
607130973	DP13-124	10 X 24 X 1	9-3/8 X 23-3/8 X 3/4	12	500	0.41	3.7
607130975	DP13-122	12 X 12 X 1	11-3/4 X 11-3/4 X 3/4	12	300	0.41	3.8
607130977	DP13-123	12 X 16 X 1	11-1/2 X 15-3/4 X 3/4	12	400	0.41	3.8
607130980	DP13-120	12 X 20 X 1	11-1/2 X 19-1/2 X 3/4	12	500	0.41	3.8
607130990	DP13-110	12 X 24 X 1	11-3/8 X 23-3/8 X 3/4	12	600	0.41	4.6
607131414	DP13-133	14 X 14 X 1	13-3/4 X 13-3/4 X 3/4	12	410	0.41	4.5
607131000	DP13-139	14 X 20 X 1	13-1/2 X 19-1/2 X 3/4	12	585	0.41	4.5
607131002	DP13-159	14 X 24 X 1	13-3/8 X 23-3/8 X 3/4	12	700	0.41	5.4
607131105	DP13-141	14 X 25 X 1	13-1/2 X 24-1/2 X 3/4	12	730	0.41	5.7
607131107	DP13-137	14 X 30 X 1	13-3/4 X 29-3/4 X 3/4	12	875	0.41	10.1
607131110	DP13-145	15 X 20 X 1	14-1/2 X 19-1/2 X 3/4	12	625	0.41	5.0
607131111	DP13-140	15 X 30 X 1	14-3/4 X 29-3/4 X 3/4	12	935	0.41	10.1
607131115	DP13-143	16 X 16 X 1	15-1/2 X 15-1/2 X 3/4	12	530	0.41	5.3
607131120	DP13-101	16 X 20 X 1	15-1/2 X 19-1/2 X 3/4	12	665	0.41	5.3
607131124	DP13-116	16 X 24 X 1	15-3/8 X 23-3/8 X 3/4	12	800	0.41	6.3
607131130	DP13-102	16 X 25 X 1	15-1/2 X 24-1/2 X 3/4	12	835	0.41	96.6
607131132	DP13-146	16 X 30 X 1	15-3/4 X 29-3/4 X 3/4	12	1000	0.41	10.1
607131818	DP13-163	18 X 18 X 1	17-3/4 X 17-3/4 X 3/4	12	675	0.41	6.0
607131135	DP13-180	18 X 20 X 1	17-3/8 X 19-1/2 X 3/4	12	750	0.41	6.0
607131137	DP13-182	18 X 22 X 1	17-3/8 X 21-1/2 X 3/4	12	825	0.41	7.2
607131140	DP13-112	18 X 24 X 1	17-3/8 X 23-3/8 X 3/4	12	900	0.41	7.2
607131145	DP13-185	18 X 25 X 1	17-1/2 X 24-1/2 X 3/4	12	935	0.41	7.5
607131150	DP13-103	20 X 20 X 1	19-1/2 X 19-1/2 X 3/4	12	830	0.41	6.7
607131155	DP13-166	20 X 22 X 1	19-3/4 X 21-3/4 X 3/4	12	915	0.41	8.0
607131165	DP13-111	20 X 24 X 1	19-3/8 X 23-3/8 X 3/4	12	1000	0.41	8.0
607131170	DP13-104	20 X 25 X 1	19-1/2 X 24-1/2 X 3/4	12	1040	0.41	8.4
607131195	DP13-151	22 X 22 X 1	21-3/4 X 21-3/4 X 3/4	12	1250	0.41	8.9
607131175	DP13-132	30 X 20 X 1	29-1/2 X 19-1/2 X 3/4	12	1005	0.41	10.1
607131180	DP13-105	24 X 24 X 1	23-3/8 X 23-3/8 X 3/4	12	1200	0.41	9.5
607131185	DP13-153	24 X 30 X 1	23-3/4 X 29-1/4 X 3/4	12	1500	0.41	12.0
607131190	DP13-125	25 X 25 X 1	24-1/2 X 24-1/2 X 3/4	12	1300	0.41	10.5
Brauer P/N	AG P/N	Nominal Size	Exact Size	Carton Qty	Rated Air Flow CFM	Initial Resistance	Media Area
607132110	DP13-217	10 X 20 X 2	9-1/2 X 19-1/2 X 1-3/4	12	700	0.41	7.2
607132115	DP13-220	12 X 20 X 2	11-1/2 X 19-1/2 X 1-3/4	12	840	0.41	8.8
607132120	DP13-210	12 X 24 X 2	11-3/8 X 19-3/8 X 1-3/4	12	1000	0.41	10.5
607132130	DP13-239	14 X 20 X 2	13-1/2 X 19-1/2 X 1-3/4	12	980	0.41	10.4
607132140	DP13-241	14 X 25 X 2	13-1/2 X 24-1/2 X 1-3/4	12	1220	0.41	13.0
607132160	DP13-245	15 X 20 X 2	14-1/2 X 19-1/2 X 1-3/4	12	1050	0.41	20.0
607132190	DP13-201	16 X 20 X 2	15-1/2 X 19-1/2 X 1-3/4	12	1120	0.41	10.9
607132215	DP13-216	16 X 24 X 2	15-3/8 X 19-3/8 X 1-3/4	12	1340	0.41	13.7
607132220	DP13-202	16 X 25 X 2	15-1/2 X 24-1/2 X 1-3/4	12	1400	0.41	14.9
607132225	DP13-280	18 X 20 X 2	17-1/2 X 19-1/2 X 1-3/4	12	1250	0.41	13.0
607132240	DP13-212	18 X 24 X 2	17-3/8 X 23-3/8 X 1-3/4	12	1500	0.41	15.5
607132245	DP13-285	18 X 25 X 2	17-1/2 X 24-1/2 X 1-3/4	12	1570	0.41	16.2
607132260	DP13-203	20 X 20 X 2	19-1/2 X 19-1/2 X 1-3/4	12	1400	0.41	14.5
607132270	DP13-211	20 X 24 X 2	19-3/8 X 23-3/8 X 1-3/4	12	1670	0.41	17.4
607132280	DP13-204	20 X 25 X 2	19-1/2 X 24-1/2 X 1-3/4	12	1750	0.41	18.2
607132285	DP13-232	20 X 30 X 2	19-1/2 X 29-1/2 X 1-3/4	12	2080	0.41	22.3
607132370	DP13-205	24 X 24 X 2	23-3/8 X 23-3/8 X 1-3/4	12	2000	0.41	21.1
607132380	DP13-225	25 X 25 X 2	24-1/2 X 24-1/2 X 1-3/4	12	2170	0.41	23.4
Brauer P/N	AG P/N	Nominal Size	Exact Size	Carton Qty	Rated Air Flow CFM	Initial Resistance	Media Area
607134170	DP13-410	12 X 24 X 4	11-3/8 X 23-3/8 X 3-3/4	6	1000	0.34	12.4
607134190	DP13-401	16 X 20 X 4	15-1/2 X 19-1/2 X 3-3/4	6	1120	0.34	14.6
607134220	DP13-402	16 X 25 X 4	15-1/2 X 24-1/2 X 3-3/4	6	1400	0.34	18.3
607134238	DP13-412	18 X 24 X 4	17-3/8 X 23-3/8 X 3-3/4	6	1500	0.34	19.9
607134260	DP13-403	20 X 20 X 4	19-1/2 X 19-1/2 X 3-3/4	6	1400	0.34	18.8
607134270	DP13-411	20 X 24 X 4	19-3/8 X 23-3/8 X 3-3/4	6	1670	0.34	22.4
607134280	DP13-404	20 X 25 X 4	19-1/2 X 24-1/2 X 3-3/4	6	1750	0.34	23.5
6071324244	DP13-405	24 X 24 X 4	23-3/8 X 23-3/8 X 3-3/4	6	2000	0.34	27.4

Also available in special sizes.





Type DPGT

- \* MERV 8
- \* Blend of multi-denier synthetic fibers
- \* Reinforced die cut beverage board frame
- \* 30-35% efficiency



DP-65, DP-85, DP-95 High Eff.

- \* Ultrafine fiberglass media
- \* 2" and 4" depths available
- \* Die cut beverage board frame
- \* Three efficiencies 50-55%, 75-80%, 80-85%
- \* DP-85, DP-95 recommended for low velocity applications
- \* 4" thick DP-65 provides highest efficiency available in a pleated filter operating at 500 FPM (50-55%)



DP4-SA Side Access Filter

- \* Same construction as standard Type DP
- \* 4" depth available
- \* 1" header on top and bottom is designed for installation in side access systems
- \* Available in 25-30% and 35-40% efficiencies



DP1

- \* Classified per U.L. Standard 900
- \* Ultrafine fiberglass media
- \* 1", 2" and 4" depths available
- \* Non-flammable die cut board frame
- \* Available with Standard DP and DP Max pleat counts
- \* 35-40% efficiency



DPHT High Temperature

- \* Operates up to 500°F
- \* Ultrafine fiberglass media
- \* 1", 2" and 4" depths available
- \* Aluminized steel frame
- \* Available with Standard DP and DP Max pleat counts
- \* 35-40% efficiency



Bio-Pure

- \* 1", 2" and 4" depths available
- \* Available in 14.5 and 10 pleats per foot (2")
- \* 25-30% efficiency

# XL8-SC STANDARD CAPACITY PLEATED FILTER MERV 8



Low resistance to airflow, high dust holding capacity, sturdy double-wall frame design, and moisture resistant beverage board frame.

Brauer P/N	Koch P/N	Nominal Size	Exact Size	Capacity			Carton Qty	Resistance			Media Area	Weight
				Low	Med	High		Low	Med	High		
6370110970	102-700-001	10 X 20 X 1	9-1/2 X 19-1/2 X 3/4	425	700	NR	12	0.26	0.51	NR	2.3	7
6370110980	102-041-002	12 X 20 X 1	11-1/2 X 19-1/2 X 3/4	500	840	NR	12	0.26	0.51	NR	2.8	12
6370110990	102-700-002	12 X 24 X 1	11-3/8 X 23-3/8 X 3/4	600	1000	NR	12	0.26	0.51	NR	3.3	9
6370111000	102-700-003	14 X 20 X 1	13-1/2 X 19-1/2 X 3/4	590	980	NR	12	0.26	0.51	NR	3.3	11
6370111105	102-700-004	14 X 25 X 1	13-1/2 X 24-1/2 X 3/4	730	1215	NR	12	0.26	0.51	NR	4.1	13
6370111110	102-700-005	15 X 20 X 1	14-1/2 X 19-1/2 X 3/4	625	1050	NR	12	0.26	0.51	NR	3.5	11
6370111120	102-700-006	16 X 20 X 1	15-1/2 X 19-1/2 X 3/4	670	1115	NR	12	0.26	0.51	NR	3.8	11
6370111130	102-700-007	16 X 25 X 1	15-1/2 X 24-1/2 X 3/4	840	1400	NR	12	0.26	0.51	NR	4.7	12
6370111140	102-041-016	18 X 24 X 1	17-3/8 X 23-3/8 X 3/4	900	1500	NR	12	0.26	0.51	NR	5.1	14
6370111145	102-041-011	18 X 25 X 1	17-1/2 X 24-1/2 X 3/4	940	1570	NR	12	0.26	0.51	NR	5.3	14
6370111150	102-700-008	20 X 20 X 1	19-1/2 X 19-1/2 X 3/4	840	1400	NR	12	0.26	0.51	NR	4.8	12
6370111170	102-700-009	20 X 25 X 1	19-1/2 X 24-1/2 X 3/4	1050	1740	NR	12	0.26	0.51	NR	6.0	13
6370111180	102-700-010	24 X 24 X 1	23-3/8 X 23-3/8 X 3/4	1200	2000	NR	12	0.26	0.51	NR	6.8	14
6370111190	102-041-014	25 X 25 X 1	24-1/2 X 24-1/2 X 3/4	1310	2170	NR	12	0.26	0.51	NR	7.4	16
Brauer P/N	Koch P/N	Nominal Size	Exact Size	Capacity			Carton Qty	Resistance			Media Area	Weight
				Low	Med	High		Low	Med	High		
6370112110	102-700-011	10 X 20 X 2	9-1/2 X 19-1/2 X 1-3/4	425	700	875	12	0.14	0.25	0.34	4.0	8
6370112115	102-042-002	12 X 20 X 2	11-1/2 X 19-1/2 X 1-3/4	500	840	1050	12	0.14	0.25	0.34	4.8	8
6370112120	102-700-012	12 X 24 X 2	11-3/8 X 23-3/8 X 1-3/4	600	1000	1250	12	0.14	0.25	0.34	5.7	10
6370112130	102-700-013	14 X 20 X 2	13-1/2 X 19-1/2 X 1-3/4	590	980	1215	12	0.14	0.25	0.34	5.6	10
6370112140	102-700-014	14 X 25 X 2	13-1/2 X 24-1/2 X 1-3/4	730	1215	1520	12	0.14	0.25	0.34	7.1	11
6370112160	102-700-015	15 X 20 X 2	14-1/2 X 19-1/2 X 1-3/4	625	1050	1310	12	0.14	0.25	0.34	6.1	11
6370112190	102-700-016	16 X 20 X 2	15-1/2 X 19-1/2 X 1-3/4	670	115	1400	12	0.14	0.25	0.34	6.7	12
6370112215	102-700-053	16 X 24 X 2	15-1/2 X 23-1/2 X 1-3/4	800	1350	1675	12	0.14	0.25	0.34	7.8	10
6370112220	102-700-017	16 X 25 X 2	15-1/2 X 24-1/2 X 1-3/4	840	1400	1740	12	0.14	0.25	0.34	8.1	13
6370112240	102-700-018	18 X 24 X 2	17-1/2 X 23-1/2 X 1-3/4	900	1500	1875	12	0.14	0.25	0.34	8.8	15
6370112245	102-042-009	18 X 25 X 2	17-1/2 X 24-1/2 X 1-3/4	950	1570	1960	12	0.14	0.25	0.34	9.1	11
6370112260	102-700-019	20 X 20 X 2	19-1/2 X 19-1/2 X 1-3/4	840	1400	1740	12	0.14	0.25	0.34	8.3	13
6370112270	102-700-020	20 X 24 X 2	19-1/2 X 23-1/2 X 1-3/4	1000	1675	2100	12	0.14	0.25	0.34	9.8	15
6370112280	102-700-021	20 X 25 X 2	19-1/2 X 24-1/2 X 1-3/4	1050	1740	2170	12	0.14	0.25	0.34	10.5	15
6370112370	102-700-022	24 X 24 X 2	23-3/8 X 23-3/8 X 1-3/4	1200	2000	2500	12	0.14	0.25	0.34	11.8	17
6370112380	102-700-050	25 X 25 X 2	24-1/2 X 24-1/2 X 1-3/4	1310	2170	2720	12	0.14	0.25	0.34	12.8	12
Brauer P/N	Koch P/N	Nominal Size	Exact Size	Capacity			Carton Qty	Resistance			Media Area	Weight
				Low	Med	High		Low	Med	High		
6370114170	102-700-023	12 X 24 X 4	11-3/8 X 23-3/8 X 3-3/4	600	1000	1250	6	0.09	0.18	0.25	10.6	10
6370114190	102-700-024	16 X 20 X 4	15-1/2 X 19-1/2 X 3-3/4	670	1115	1400	6	0.09	0.18	0.25	12.0	11
6370114191	102-700-025	16 X 24 X 4	15-3/8 X 23-3/8 X 3-3/4	800	1350	1675	6	0.09	0.18	0.25	14.3	11
6370114220	102-700-026	16 X 25 X 4	15-1/2 X 24-1/2 X 3-3/4	840	1400	1750	6	0.09	0.18	0.25	15.0	14
6370114238	102-700-027	18 X 24 X 4	17-1/2 X 23-3/8 X 3-3/4	900	1500	1875	6	0.09	0.18	0.25	16.3	13
6370114260	102-700-028	20 X 20 X 4	19-1/2 X 19-1/2 X 3-3/4	840	1400	1740	6	0.09	0.18	0.25	15.1	14
6370114270	102-700-029	20 X 24 X 4	19-1/2 X 23-3/8 X 3-3/4	1000	1675	2100	6	0.09	0.18	0.25	18.1	15
6370114280	102-700-030	20 X 25 X 4	19-1/2 X 24-1/2 X 3-3/4	1050	1740	2170	6	0.09	0.18	0.25	19.5	15
6370114370	102-700-031	24 X 24 X 4	23-3/8 X 23-3/8 X 3-3/4	1200	2000	2500	6	0.09	0.18	0.25	22.5	17



Semi Standard Sizes				
Brauer P/N	Koch P/N	Nominal Size	Carton Qty	Weight
6370110960	102-041-020	10 x 10 x 1	12	10
6370110975	102-700-051	12 x 12 x 1	12	10
6370110978	102-041-001	12 x 18 x 1	12	11
6370110991	102-041-003	12 x 25 x 1	12	14
6370111414	102-041-004	14 x 14 x 1	12	11
6370111002	102-041-005	14 x 24 x 1	12	15
6370111111	102-041-006	15 x 25 x 1	12	16
6370111115	102-041-007	16 x 16 x 1	12	13
6370111124	102-041-008	16 x 24 x 1	12	14
6370111132	102-041-018	16 x 30 x 1	12	15
6370111818	102-041-009	18 x 18 x 1	12	14
6370111135	102-041-015	18 x 20 x 1	12	14
6370111165	102-041-017	20 x 24 x 1	12	14
6370111175	102-041-012	20 x 30 x 1	12	16
6370111185	102-041-013	24 x 30 x 1	12	16
Brauer P/N	Koch P/N	Nominal Size	Carton Qty	Weight
6370112117	102-042-035	12 x 12 x 2	12	8
6370112121	102-042-003	12 x 25 x 2	12	10
6370112175	102-042-005	16 x 16 x 2	12	8
6370112221	102-042-018	16 x 30 x 2	12	12
6370112222	102-042-007	18 x 18 x 2	12	10
6370112285	102-042-010	20 x 30 x 2	12	13
6370112371	102-042-011	24 x 30 x 2	12	14
6370112372	102-042-012	25 x 30 x 2	12	15
Brauer P/N	Koch P/N	Nominal Size	Carton Qty	Weight
6370114371	102-044-010	25 x 29 x 4	6	19

Also available in special sizes.

## XL8-HC HIGH CAPACITY PLEATED FILTER MERV 8

30% more media, low resistance to airflow, high dust holding capacity, sturdy double-wall frame design, and moisture resistant beverage board frame.



Brauer P/N	Koch P/N	Nominal Size	Exact Size	Capacity			Carton Qty	Resistance			Media Area	Weight
				Low	Med	High		Low	Med	High		
637210970	102-701-001	10 X 20 X 1	9-1/2 X 19-1/2 X 3/4	425	700	NR	12	0.21	0.41	NR	2.9	7
637210980	102-031-002	12 X 20 X 1	11-1/2 X 19-1/2 X 3/4	500	840	NR	12	0.21	0.41	NR	3.5	12
637210990	102-701-002	12 X 24 X 1	11-3/8 X 23-3/8 X 3/4	600	1000	NR	12	0.21	0.41	NR	4.2	9
637211000	102-701-003	14 X 20 X 1	13-1/2 X 19-1/2 X 3/4	590	980	NR	12	0.21	0.41	NR	4.1	11
637211105	102-701-004	14 X 25 X 1	13-1/2 X 24-1/2 X 3/4	730	1215	NR	12	0.21	0.41	NR	5.1	13
637211110	102-701-005	15 X 20 X 1	14-1/2 X 19-1/2 X 3/4	625	1050	NR	12	0.21	0.41	NR	4.4	11
637211120	102-701-006	16 X 20 X 1	15-1/2 X 19-1/2 X 3/4	670	1115	NR	12	0.21	0.41	NR	4.7	11
637211130	102-701-007	16 X 25 X 1	15-1/2 X 24-1/2 X 3/4	840	1400	NR	12	0.21	0.41	NR	5.9	12
637211140	102-031-016	18 X 24 X 1	17-3/8 X 23-3/8 X 3/4	900	1500	NR	12	0.21	0.41	NR	<b>6.3</b>	14
637211145	102-031-011	18 X 25 X 1	17-1/2 X 24-1/2 X 3/4	940	1570	NR	12	0.21	0.41	NR	6.6	14
637211150	102-701-008	20 X 20 X 1	19-1/2 X 19-1/2 X 3/4	840	1400	NR	12	0.21	0.41	NR	5.9	12
637211170	102-701-009	20 X 25 X 1	19-1/2 X 24-1/2 X 3/4	1050	1740	NR	12	0.21	0.41	NR	7.4	13
637211180	102-701-010	24 X 24 X 1	23-3/8 X 23-3/8 X 3/4	1200	2000	NR	12	0.21	0.41	NR	8.5	14
637211190	102-031-014	25 X 25 X 1	24-1/2 X 24-1/2 X 3/4	1310	2170	NR	12	0.21	0.41	NR	9.3	16



Brauer P/N	Koch P/N	Nominal Size	Exact Size	Capacity			Carton Qty	Resistance			Media Area	Weight
				Low	Med	High		Low	Med	High		
637212110	102-701-011	10 X 20 X 2	9-1/2 X 19-1/2 X 1-3/4	425	700	875	12	0.09	0.18	0.25	6.0	8
637212115	102-032-002	12 X 20 X 2	11-1/2 X 19-1/2 X 1-3/4	500	840	1050	12	0.09	0.18	0.25	7.2	8
637212120	102-701-012	12 X 24 X 2	11-3/8 X 23-3/8 X 1-3/4	600	1000	1250	12	0.09	0.18	0.25	8.6	10
637212130	102-701-013	14 X 20 X 2	13-1/2 X 19-1/2 X 1-3/4	590	980	1215	12	0.09	0.18	0.25	8.4	10
637212140	102-701-014	14 X 25 X 2	13-1/2 X 24-1/2 X 1-3/4	730	1215	1520	12	0.09	0.18	0.25	10.6	11
637212160	102-701-015	15 X 20 X 2	14-1/2 X 19-1/2 X 1-3/4	625	1050	1310	12	0.09	0.18	0.25	9.1	11
637212190	102-701-016	16 X 20 X 2	15-1/2 X 19-1/2 X 1-3/4	670	115	1400	12	0.09	0.18	0.25	9.9	12
637212215	102-701-053	16 X 24 X 2	15-1/2 X 23-1/2 X 1-3/4	800	1350	1675	12	0.09	0.18	0.25	11.6	10
637212220	102-701-017	16 X 25 X 2	15-1/2 X 24-1/2 X 1-3/4	840	1400	1740	12	0.09	0.18	0.25	12.1	13
637212240	102-701-018	18 X 24 X 2	17-1/2 X 23-1/2 X 1-3/4	900	1500	1875	12	0.09	0.18	0.25	13.1	15
637212245	102-032-009	18 X 25 X 2	17-1/2 X 24-1/2 X 1-3/4	950	1570	1960	12	0.09	0.18	0.25	13.7	11
637212260	102-701-019	20 X 20 X 2	19-1/2 X 19-1/2 X 1-3/4	840	1400	1740	12	0.09	0.18	0.25	12.4	13
637212270	102-701-020	20 X 24 X 2	19-1/2 X 23-1/2 X 1-3/4	1000	1675	2100	12	0.09	0.18	0.25	14.6	15
637212280	102-701-021	20 X 25 X 2	19-1/2 X 24-1/2 X 1-3/4	1050	1740	2170	12	0.09	0.18	0.25	15.5	15
637212370	102-701-022	24 X 24 X 2	23-3/8 X 23-3/8 X 1-3/4	1200	2000	2500	12	0.09	0.18	0.25	17.9	17
637212380	102-701-050	25 X 25 X 2	24-1/2 X 24-1/2 X 1-3/4	1310	2170	2720	12	0.09	0.18	0.25	19.1	12

Brauer P/N	Koch P/N	Nominal Size	Exact Size	Capacity			Carton Qty	Resistance			Media Area	Weight
				Low	Med	High		Low	Med	High		
637214170	102-701-023	12 X 24 X 4	11-3/8 X 23-3/8 X 3-3/4	600	1000	1250	6	0.08	0.16	0.23	12.9	10
637214190	102-701-025	16 X 20 X 4	15-1/2 X 19-1/2 X 3-3/4	670	1115	1400	6	0.08	0.16	0.23	14.7	11
637214191	102-034-005	16 X 24 X 4	15-3/8 X 23-3/8 X 3-3/4	800	1350	1675	6	0.08	0.16	0.23	17.5	14
637214220	102-701-026	16 X 25 X 4	15-1/2 X 24-1/2 X 3-3/4	840	1400	1750	6	0.08	0.16	0.23	18.4	14
637214238	102-701-027	18 X 24 X 4	17-1/2 X 23-3/8 X 3-3/4	900	1500	1875	6	0.08	0.16	0.23	19.9	13
637214260	102-701-028	20 X 20 X 4	19-1/2 X 19-1/2 X 3-3/4	840	1400	1740	6	0.08	0.16	0.23	18.4	14
637214270	102-701-029	20 X 24 X 4	19-1/2 X 23-3/8 X 3-3/4	1000	1675	2100	6	0.08	0.16	0.23	22.2	15
637214280	102-701-030	20 X 25 X 4	19-1/2 X 24-1/2 X 3-3/4	1050	1740	2170	6	0.08	0.16	0.23	23.6	15
637214370	102-701-031	24 X 24 X 4	23-3/8 X 23-3/8 X 3-3/4	1200	2000	2500	6	0.08	0.16	0.23	27.5	17

Semi Standard Sizes				
Brauer P/N	Koch P/N	Nominal Size	Carton Qty	Weight
637210960	102-031-020	10 x 10 x 1	12	10
637210975	102-701-051	12 x 12 x 1	12	10
637210978	102-031-001	12 x 18 x 1	12	11
637210991	102-031-003	12 x 25 x 1	12	14
637211414	102-031-004	14 x 14 x 1	12	11
637211002	102-031-005	14 x 24 x 1	12	15
637211111	102-031-006	15 x 25 x 1	12	16
637211115	102-031-007	16 x 16 x 1	12	13
637211124	102-031-008	16 x 24 x 1	12	14
637211132	102-031-018	16 x 30 x 1	12	15
637211818	102-031-009	18 x 18 x 1	12	14
637211135	102-031-015	18 x 20 x 1	12	14
637211165	102-031-017	20 x 24 x 1	12	14
637211175	102-031-012	20 x 30 x 1	12	16
637211185	102-031-013	24 x 30 x 1	12	16
Brauer P/N	Koch P/N	Nominal Size	Carton Qty	Weight
637212117	102-032-035	12 x 12 x 2	12	8
637212121	102-032-003	12 x 25 x 2	12	10
637212175	102-032-005	16 x 16 x 2	12	8
637212221	102-032-018	16 x 30 x 2	12	12
637212222	102-032-007	18 x 18 x 2	12	10
637212285	102-032-010	20 x 30 x 2	12	13
637212371	102-032-011	24 x 30 x 2	12	14
637212372	102-032-012	25 x 30 x 2	12	15
Brauer P/N	Koch P/N	Nominal Size	Carton Qty	Weight
637214371	102-034-010	25 x 29 x 4	6	19

Also available in special sizes.



Series K-40

- \* Designed for value and economy
- \* Ideal for filter service programs and preventative maintenance
  - \* Moisture resistant
  - \* Extended service life
  - \* Completely disposable



Trion Airbear and Honeywell & Spaceguard

- \* Replacement filters for Trion Airbear and Air Cub
- \* Replacement filters for Honeywell F-Series
- \* Replacement filters for Aprilaire Space-Guard media



Multi-Pleat Elite

- \* Exclusive vForm Pleating Technology
- \* MERV 8 performance rating
- \* Self-supporting pleats requires no metal reinforcement
- \* Low resistance to airflow reduces energy costs
- \* Moisture-resistance beverage board frame
- \* Completely incinerable



XL11-SC & HC

- \* Upgrade from standard pleated filter
  - \* MERV 11 efficiency rating
  - \* Dual-layered filter media
  - \* Low pressure drop
  - \* Superior efficiency
  - \* High dust holding capacity



Green 13

- \* MERV 13 performance rating
  - \* Earns LEED points
  - \* Reduces energy cost
  - \* Extended filter lifecycle
  - \* Conserves resources
- \* Improves indoor environmental quality



Multi-Pleat GT

- \* Upgraded performance and efficiency
  - \* MERV 8 performance rating
- \* Upstream support fingers for improved stability
  - \* Wet-strength beverage-board frame construction
- \* Heavy-duty expanded metal support grid



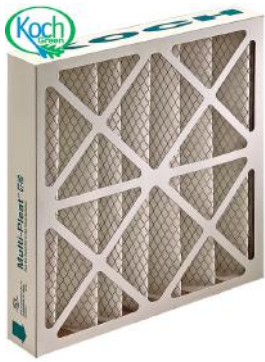

**Multi-Pleat GT-HD**

- \* MERV 8 performance rating
- \* Superior performance
- \* Two synthetic media options
- \* Durable .056" beverage board frame construction
- \* Heavy duty expanded metal backing
- \* Inserts available for pad holding frames
- \* Engineered versatility



**Multi-Pleat HT/Class 1**

- \* MERV 8
- \* For ovens and air filtration with continuous operational temperatures up to 500 F
- \* Used in paint booths, baking systems, drying ovens
- \* Medium eff. extended surface media element secured in a 24 gauge aluminized steel enclosure frame to resist flaking



**XL8HC-SA**

- \* Constructed of high wet-strength, moisture resistant beverage board
- \* Die-cut frame provides superior strength durability
- \* 3/16" peripheral header for easy installation
- \* Available in MERV 8, MERV 11 and MERV 13
- \* Media strength, high dust holding capacity, and low resistance to air flow

**3M PURIFICATION**

**MERV A13 with Gasket performance data**

- \* Air velocity for ASHRAE testing: 492 fpm (1968 cfm for 24 x 24 filter)
- \* Initial pressure drop: 0.39" w.g.
- \* Recommended final pressure drop: 1.4" w.g.
- \* Efficiency rating per ASHRAE 52.2: 2007: MERV 14
- \* Efficiency rating per ASHRAE 52.2: 2007 appendix J: MERV A13
- \* Dust holding capacity at 1.4" w.g.: 95 +/- 7 g

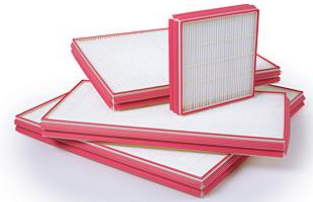

Brauer P/N	Product #	3M P/N	Nominal Size	Exact Size	Carton Qty
60771675	E675	70-0714-7119-0	10 X 10 X 2	9-3/8 X 9-3/8 X 1-7/8	5
60771676	E676	70-0714-7120-8	10 X 20 X 2	9-3/8 X 19-3/8 X 1-7/8	5
60771677	E677	70-0714-7121-6	12 X 20 X 2	11-3/8 X 19-3/8 X 1-7/8	5
60771678	E678	70-0714-7122-4	12 X 24 X 2	11-3/8 X 23-3/8 X 1-7/8	5
60771679	E679	70-0714-7123-2	14 X 20 X 2	13-3/8 X 19-3/8 X 1-7/8	5
60771680	E680	70-0714-7124-0	14 X 25 X 2	13-3/8 X 24-3/8 X 1-7/8	5
60771681	E681	70-0714-7125-7	15 X 20 X 2	14-3/8 X 19-3/8 X 1-7/8	5
60771682	E682	70-0714-7126-5	16 X 16 X 2	15-3/8 X 15-3/8 X 1-7/8	5
60771683	E683	70-0714-7127-3	16 X 20 X 2	15-3/8 X 19-3/8 X 1-7/8	5
60771684	E684	70-0714-7128-1	16 X 24 X 2	15-3/8 X 23-3/8 X 1-7/8	5
60771685	E685	70-0714-7129-9	16 X 25 X 2	15-3/8 X 24-3/8 X 1-7/8	5
60771686	E686	70-0714-7130-7	18 X 20 X 2	17-3/8 X 19-3/8 X 1-7/8	5
60771687	E687	70-0714-7131-5	18 X 24 X 2	17-3/8 X 23-3/8 X 1-7/8	5
60771688	E688	70-0714-7132-3	18 X 25 X 2	19-3/8 X 24-3/8 X 1-7/8	5
60771689	E689	70-0714-7133-1	20 X 20 X 2	19-3/8 X 19-3/8 X 1-7/8	5
60771690	E690	70-0714-7134-9	20 X 24 X 2	19-3/8 X 23-3/8 X 1-7/8	5
60771691	E691	70-0714-7135-6	20 X 25 X 2	19-3/8 X 24-3/8 X 1-7/8	5
60771694	E694	70-0714-7138-0	20 X 30 X 2	19-3/8 X 29-3/8 X 1-7/8	5
60771692	E692	70-0714-7136-4	24 X 24 X 2	23-3/8 X 23-3/8 X 1-7/8	5
60771693	E693	70-0714-7137-2	25 X 25 X 2	24-3/8 X 24-3/8 X 1-7/8	5



MERV A12 with Gasket performance data

- \* Air velocity for ASHRAE testing: 492 fpm (1968 cfm for 24 x 24 filter)
- \* Initial pressure drop: 0.37" w.g.
- \* Recommended final pressure drop: 1.4" w.g.
- \* Efficiency rating per ASHRAE 52.2: 2007: MERV 14
- \* Efficiency rating per ASHRAE 52.2: 2007 appendix J: MERV A12
- \* Dust holding capacity at 1.4" w.g.: 93 +/- 21 g

Brauer P/N	Product #	3M P/N	Nominal Size	Exact Size	Carton Qty
60771133	E133	70-0708-1943-1	10 X 10 X 2	9-3/8 X 9-3/8 X 1-7/8	5
60771124	E124	70-0708-1934-0	10 X 20 X 2	9-3/8 X 19-3/8 X 1-7/8	5
60771125	E125	70-0708-1935-7	12 X 20 X 2	11-3/8 X 19-3/8 X 1-7/8	5
60771978	F978	70-0708-1806-0	12 X 24 X 2	11-3/8 X 23-3/8 X 1-7/8	5
60771126	E126	70-0708-1936-5	14 X 20 X 2	13-3/8 X 19-3/8 X 1-7/8	5
60771127	E127	70-0708-1937-3	14 X 25 X 2	13-3/8 X 24-3/8 X 1-7/8	5
60771136	E136	70-0708-1946-4	15 X 20 X 2	14-3/8 X 19-3/8 X 1-7/8	5
60771128	E128	70-0708-1938-1	16 X 16 X 2	15-3/8 X 15-3/8 X 1-7/8	5
60771979	F979	70-0708-1807-8	16 X 20 X 2	15-3/8 X 19-3/8 X 1-7/8	5
60771129	E129	70-0708-1939-9	16 X 24 X 2	15-3/8 X 23-3/8 X 1-7/8	5
60771980	F980	70-0708-1808-6	16 X 25 X 2	15-3/8 X 24-3/8 X 1-7/8	5
60771132	E132	70-0708-1942-3	18 X 20 X 2	17-3/8 X 19-3/8 X 1-7/8	5
60771981	F981	70-0708-1890-4	18 X 24 X 2	17-3/8 X 23-3/8 X 1-7/8	5
60771130	E130	70-0708-1940-7	18 X 25 X 2	19-3/8 X 24-3/8 X 1-7/8	5
60771977	F977	70-0708-1805-2	20 X 20 X 2	19-3/8 X 19-3/8 X 1-7/8	5
60771131	E131	70-0708-1941-5	20 X 24 X 2	19-3/8 X 23-3/8 X 1-7/8	5
60771982	F982	70-0708-1810-2	20 X 25 X 2	19-3/8 X 24-3/8 X 1-7/8	5
60771134	E134	70-0708-1944-9	20 X 30 X 2	19-3/8 X 29-3/8 X 1-7/8	5
60771976	F976	70-0708-1804-5	24 X 24 X 2	23-3/8 X 23-3/8 X 1-7/8	5
60771135	E135	70-0708-1945-6	25 X 25 X 2	24-3/8 X 24-3/8 X 1-7/8	5

MERV A11 with Gasket performance data

- \* Air velocity for ASHRAE testing: 492 fpm (1968 cfm for 24 x 24 filter)
- \* Initial pressure drop: 0.25" w.g.
- \* Recommended final pressure drop: 1.4" w.g.
- \* Efficiency rating per ASHRAE 52.2: 2007: MERV 12
- \* Efficiency rating per ASHRAE 52.2: 2007 appendix J: MERV A11
- \* Dust holding capacity at 1.4" w.g.: 110 +/- 17 g





Brauer P/N	Product #	3M P/N	Nominal Size	Exact Size	Carton Qty
60771695	E695	70-0714-7139-8	10 X 10 X 2	9-3/8 X 9-3/8 X 1-7/8	5
60771696	E696	70-0714-7140-6	10 X 20 X 2	9-3/8 X 19-3/8 X 1-7/8	5
60771697	E697	70-0714-7141-4	12 X 20 X 2	11-3/8 X 19-3/8 X 1-7/8	5
60771698	E698	70-0714-7142-2	12 X 24 X 2	11-3/8 X 23-3/8 X 1-7/8	5
60771699	E699	70-0714-7143-0	14 X 20 X 2	13-3/8 X 19-3/8 X 1-7/8	5
60771700	E700	70-0714-7144-8	14 X 25 X 2	13-3/8 X 24-3/8 X 1-7/8	5
60771701	E701	70-0714-7145-5	15 X 20 X 2	14-3/8 X 19-3/8 X 1-7/8	5
60771702	E702	70-0714-7146-3	16 X 16 X 2	15-3/8 X 15-3/8 X 1-7/8	5
60771703	E703	70-0714-7147-1	16 X 20 X 2	15-3/8 X 19-3/8 X 1-7/8	5
60771704	E704	70-0714-7148-9	16 X 24 X 2	15-3/8 X 23-3/8 X 1-7/8	5
60771705	E705	70-0714-7149-7	16 X 25 X 2	15-3/8 X 24-3/8 X 1-7/8	5
60771706	E706	70-0714-7150-5	18 X 20 X 2	17-3/8 X 19-3/8 X 1-7/8	5
60771707	E707	70-0714-7151-3	18 X 24 X 2	17-3/8 X 23-3/8 X 1-7/8	5
60771708	E708	70-0714-7152-1	18 X 25 X 2	19-3/8 X 24-3/8 X 1-7/8	5
60771709	E709	70-0714-7153-9	20 X 20 X 2	19-3/8 X 19-3/8 X 1-7/8	5
60771710	E710	70-0714-7154-7	20 X 24 X 2	19-3/8 X 23-3/8 X 1-7/8	5
60771711	E711	70-0714-7155-4	20 X 25 X 2	19-3/8 X 24-3/8 X 1-7/8	5
60771714	E714	70-0714-7158-8	20 X 30 X 2	19-3/8 X 29-3/8 X 1-7/8	5
60771712	E712	70-0714-7156-2	24 X 24 X 2	23-3/8 X 23-3/8 X 1-7/8	5
60771713	E713	70-0714-7157-0	25 X 25 X 2	24-3/8 X 24-3/8 X 1-7/8	5

MERV A8 with Gasket performance data

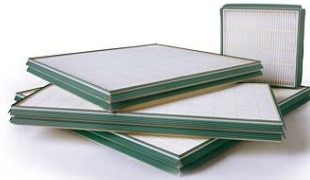

- \* Air velocity for ASHRAE testing: 492 fpm (1968 cfm for 24 x 24 filter)
- \* Initial pressure drop: 0.26" w.g.
- \* Recommended final pressure drop: 1.4" w.g.
- \* Efficiency rating per ASHRAE 52.2: 2007: MERV 11
- \* Efficiency rating per ASHRAE 52.2: 2007 appendix J: MERV A8
- \* Dust holding capacity at 1.4" w.g.: 90 +/- 15 g

Brauer P/N	Product #	3M P/N	Nominal Size	Exact Size	Carton Qty
60771276	E276	70-0712-4438-1	10 X 10 X 2	9-3/8 X 9-3/8 X 1-7/8	5
60771277	E277	70-0712-4439-9	10 X 20 X 2	9-3/8 X 19-3/8 X 1-7/8	5
60771278	E278	70-0712-4440-7	12 X 20 X 2	11-3/8 X 19-3/8 X 1-7/8	5
60771279	E279	70-0712-4441-5	12 X 24 X 2	11-3/8 X 23-3/8 X 1-7/8	5
60771280	E280	70-0712-4442-3	14 X 20 X 2	13-3/8 X 19-3/8 X 1-7/8	5
60771281	E281	70-0712-4443-1	14 X 25 X 2	13-3/8 X 24-3/8 X 1-7/8	5
60771282	E282	70-0712-4444-9	15 X 20 X 2	14-3/8 X 19-3/8 X 1-7/8	5
60771283	E283	70-0712-4445-6	16 X 16 X 2	15-3/8 X 15-3/8 X 1-7/8	5
60771284	E284	70-0712-4446-4	16 X 20 X 2	15-3/8 X 19-3/8 X 1-7/8	5
60771285	E285	70-0712-4447-2	16 X 24 X 2	15-3/8 X 23-3/8 X 1-7/8	5
60771286	E286	70-0712-4448-0	16 X 25 X 2	15-3/8 X 24-3/8 X 1-7/8	5
60771287	E287	70-0712-4449-8	18 X 20 X 2	17-3/8 X 19-3/8 X 1-7/8	5
60771288	E288	70-0712-4450-6	18 X 24 X 2	17-3/8 X 23-3/8 X 1-7/8	5
60771289	E289	70-0712-4451-4	18 X 25 X 2	19-3/8 X 24-3/8 X 1-7/8	5
60771290	E290	70-0712-4452-2	20 X 20 X 2	19-3/8 X 19-3/8 X 1-7/8	5
60771291	E291	70-0712-4453-0	20 X 24 X 2	19-3/8 X 23-3/8 X 1-7/8	5
60771292	E292	70-0712-4454-8	20 X 25 X 2	19-3/8 X 24-3/8 X 1-7/8	5
60771293	E293	70-0712-4455-5	20 X 30 X 2	19-3/8 X 29-3/8 X 1-7/8	5
60771294	E294	70-0712-4456-3	24 X 24 X 2	23-3/8 X 23-3/8 X 1-7/8	5
60771295	E295	70-0712-4457-1	25 X 25 X 2	24-3/8 X 24-3/8 X 1-7/8	5



MERV A12 no Gasket performance data

- \* Air velocity for ASHRAE testing: 492 fpm (1968 cfm for 24 x 24 filter)
- \* Initial pressure drop: 0.37" w.g.
- \* Recommended final pressure drop: 1.4" w.g.
- \* Efficiency rating per ASHRAE 52.2: 2007: MERV 14
- \* Efficiency rating per ASHRAE 52.2: 2007 appendix J: MERV A12
- \* Dust holding capacity at 1.4" w.g.: 93 +- 21 g



Brauer P/N	Product #	3M P/N	Nominal Size	Exact Size	Carton Qty
60771358	E358	70-0712-4567-7	10 X 10 X 2	9-3/8 X 9-3/8 X 1-7/8	5
60771359	E359	70-0712-4568-5	10 X 20 X 2	9-3/8 X 19-3/8 X 1-7/8	5
60771360	E360	70-0712-4569-3	12 X 20 X 2	11-3/8 X 19-3/8 X 1-7/8	5
60771361	E361	70-0712-4570-1	12 X 24 X 2	11-3/8 X 23-3/8 X 1-7/8	5
60771362	E362	70-0712-4571-9	14 X 20 X 2	13-3/8 X 19-3/8 X 1-7/8	5
60771363	E363	70-0712-4572-7	14 X 25 X 2	13-3/8 X 24-3/8 X 1-7/8	5
60771364	E364	70-0712-4573-5	15 X 20 X 2	14-3/8 X 19-3/8 X 1-7/8	5
60771365	E365	70-0712-4574-3	16 X 16 X 2	15-3/8 X 15-3/8 X 1-7/8	5
60771366	E366	70-0712-4575-0	16 X 20 X 2	15-3/8 X 19-3/8 X 1-7/8	5
60771367	E367	70-0712-4576-8	16 X 24 X 2	15-3/8 X 23-3/8 X 1-7/8	5
60771368	E368	70-0712-4577-6	16 X 25 X 2	15-3/8 X 24-3/8 X 1-7/8	5
60771369	E369	70-0712-4578-4	18 X 20 X 2	17-3/8 X 19-3/8 X 1-7/8	5
60771370	E370	70-0712-4579-2	18 X 24 X 2	17-3/8 X 23-3/8 X 1-7/8	5
60771371	E371	70-0712-4580-0	18 X 25 X 2	19-3/8 X 24-3/8 X 1-7/8	5
60771372	E372	70-0712-4581-8	20 X 20 X 2	19-3/8 X 19-3/8 X 1-7/8	5
60771373	E373	70-0712-4582-6	20 X 24 X 2	19-3/8 X 23-3/8 X 1-7/8	5
60771374	E374	70-0712-4583-4	20 X 25 X 2	19-3/8 X 24-3/8 X 1-7/8	5
60771375	E375	70-0712-4584-2	20 X 30 X 2	19-3/8 X 29-3/8 X 1-7/8	5
60771376	E376	70-0712-4585-9	24 X 24 X 2	23-3/8 X 23-3/8 X 1-7/8	5
60771377	E377	70-0712-4586-7	25 X 25 X 2	24-3/8 X 24-3/8 X 1-7/8	5

MERV A8 with Gasket performance data

- \* Air velocity for ASHRAE testing: 492 fpm (1968 cfm for 24 x 24 filter)
- \* Initial pressure drop: 0.26" w.g.
- \* Recommended final pressure drop: 1.4" w.g.
- \* Efficiency rating per ASHRAE 52.2: 2007: MERV 11
- \* Efficiency rating per ASHRAE 52.2: 2007 appendix J: MERV A8
- \* Dust holding capacity at 1.4" w.g.: 90 +- 15 g



Brauer P/N	Product #	3M P/N	Nominal Size	Exact Size	Carton Qty
60771324	E324	70-0712-4480-3	10 X 10 X 2	9-3/8 X 9-3/8 X 1-7/8	5
60771325	E325	70-0712-4481-1	10 X 20 X 2	9-3/8 X 19-3/8 X 1-7/8	5
60771326	E326	70-0712-4482-9	12 X 20 X 2	11-3/8 X 19-3/8 X 1-7/8	5
60771327	E327	70-0712-4483-7	12 X 24 X 2	11-3/8 X 23-3/8 X 1-7/8	5
60771328	E328	70-0712-4484-5	14 X 20 X 2	13-3/8 X 19-3/8 X 1-7/8	5
60771329	E329	70-0712-4485-2	14 X 25 X 2	13-3/8 X 24-3/8 X 1-7/8	5
60771330	E330	70-0712-4486-0	15 X 20 X 2	14-3/8 X 19-3/8 X 1-7/8	5
60771331	E331	70-0712-4487-8	16 X 16 X 2	15-3/8 X 15-3/8 X 1-7/8	5
60771332	E332	70-0712-4540-4	16 X 20 X 2	15-3/8 X 19-3/8 X 1-7/8	5
60771333	E333	70-0712-4541-2	16 X 24 X 2	15-3/8 X 23-3/8 X 1-7/8	5
60771334	E334	70-0712-4542-0	16 X 25 X 2	15-3/8 X 24-3/8 X 1-7/8	5
60771335	E335	70-0712-4543-8	18 X 20 X 2	17-3/8 X 19-3/8 X 1-7/8	5
60771336	E336	70-0712-4544-6	18 X 24 X 2	17-3/8 X 23-3/8 X 1-7/8	5
60771337	E337	70-0712-4545-3	18 X 25 X 2	19-3/8 X 24-3/8 X 1-7/8	5
60771338	E338	70-0712-4546-1	20 X 20 X 2	19-3/8 X 19-3/8 X 1-7/8	5
60771339	E339	70-0712-4547-9	20 X 24 X 2	19-3/8 X 23-3/8 X 1-7/8	5
60771340	E340	70-0712-4548-7	20 X 25 X 2	19-3/8 X 24-3/8 X 1-7/8	5
60771341	E341	70-0712-4549-5	20 X 30 X 2	19-3/8 X 29-3/8 X 1-7/8	5
60771342	E342	70-0712-4550-3	24 X 24 X 2	23-3/8 X 23-3/8 X 1-7/8	5
60771343	E343	70-0712-4551-1	25 X 25 X 2	24-3/8 X 24-3/8 X 1-7/8	5

### High Air Flow (HAF) Filter

- \* Open channel structure
- \* Microstructured, electrostatically charged media
- \* 100% synthetic media
- \* Self supporting filter
  - \* Standard: white
  - \* Antimicrobial: green

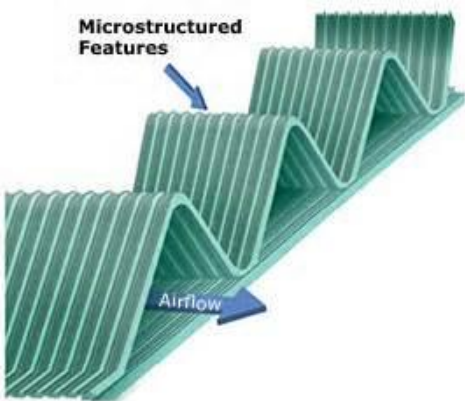



MERV A15 Performance Data

- \* Air velocity for ASHRAE testing: 492 fpm (1968 cfm for 24 x 24 filter)
- \* Initial pressure drop: 0.26" w.g.
- \* Recommended final pressure drop: 1.5" w.g.
- \* Efficiency rating per ASHRAE 52.2: 2007: MERV 16
- \* Efficiency rating per ASHRAE 52.2: 2007 appendix J: MERV A15
- \* Dust holding capacity at 1.5" w.g.: 215 g



Brauer P/N	Product #	3M P/N	Brauer P/N	Product #	3M P/N	Nominal Size	Exact Size
Standard Flow			Reverse Flow				
60771739	E739	70-0714-7184-4	60771760	E760	70-0714-7206-5	24 x 24 x 12	23-3/8 x 23-3/8 x 11.9
60771740	E740	70-0714-7185-1	60771763	E763	70-0714-7209-9	20 x 24 x 12	23-3/8 x 19-3/8 x 11.9
60771741	E741	70-0714-7186-9	60771766	E766	70-0714-7212-3	12 x 24 x 12	23-3/8 x 11-3/8 x 11.9

MERV A14 Performance Data

- \* Air velocity for ASHRAE testing: 492 fpm (1968 cfm for 24 x 24 filter)
- \* Initial pressure drop: 0.23" w.g.
- \* Recommended final pressure drop: 1.5" w.g.
- \* Efficiency rating per ASHRAE 52.2: 2007: MERV 15
- \* Efficiency rating per ASHRAE 52.2: 2007 appendix J: MERV A14
- \* Dust holding capacity at 1.5" w.g.: 235 g



Brauer P/N	Product #	3M P/N	Brauer P/N	Product #	3M P/N	Nominal Size	Exact Size
Standard Flow			Reverse Flow				
60771733	E733	70-0714-7178-6	60771759	E759	70-0714-7205-7	24 x 24 x 12	23-3/8 x 23-3/8 x 11.9
60771734	E734	70-0714-7179-4	60771762	E762	70-0714-7208-1	20 x 24 x 12	23-3/8 x 19-3/8 x 11.9
60771735	E735	70-0714-7180-2	60771765	E765	70-0714-7211-5	12 x 24 x 12	23-3/8 x 11-3/8 x 11.9

MERV A13 Performance Data

- \* Air velocity for ASHRAE testing: 492 fpm (1968 cfm for 24 x 24 filter)
- \* Initial pressure drop: 0.21" w.g.
- \* Recommended final pressure drop: 1.5" w.g.
- \* Efficiency rating per ASHRAE 52.2: 2007: MERV 14
- \* Efficiency rating per ASHRAE 52.2: 2007 appendix J: MERV A13
- \* Dust holding capacity at 1.5" w.g.: 225 g



Brauer P/N	Product #	3M P/N	Brauer P/N	Product #	3M P/N	Nominal Size	Exact Size
Standard Flow			Reverse Flow				
60771736	E736	70-0714-7181-0	60771758	E758	70-0714-7204-0	24 x 24 x 12	23-3/8 x 23-3/8 x 11.9
60771737	E737	70-0714-7182-8	60771761	E761	70-0714-7207-3	20 x 24 x 12	23-3/8 x 19-3/8 x 11.9
60771738	E738	70-0714-7183-6	60771764	E764	70-0714-7210-7	12 x 24 x 12	23-3/8 x 11-3/8 x 11.9

# PERMALAST



## Permalast Media Rolls

\* Rigid, self-supporting

\* No frame needed

\* Washable

\* Initial Resistance @300 FPM 1" = .09" & 2" = .16"

\* Recommended final resistance 1" = 1.0" & 2" = 1.0"

\* Arrestance 1" = 55-60% & 2" = 60-65%

Brauer P/N	Item #	Model #	Nominal Size	Weight	Carton Qty
600700120	1050141	P120	20" X 30' X 1"	13.0	1
600700125	1050111	P125	25" X 30' X 1"	11.0	1
600700130	1050171	P130	30" X 30' X 1"	18.0	1
600700136	1050172	P136	36" X 30' X 1"	20.0	1
600700150	1050211	P150	50" X 30' X 1"	22.0	1
600700225	1050121	P225	25" X 30' X 2"	20.0	1

## Permalast Media Pads

\* Rigid, self-supporting

\* No frame needed

\* Washable

\* Initial Resistance @300 FPM 1" = .09" & 2" = .16"

\* Recommended final resistance 1" = 1.0" & 2" = 1.0"

\* Arrestance 1" = 55-60% & 2" = 60-65%



Brauer P/N	Item #	Model #	Nominal Size	Weight	Carton Qty
600700141	0810141	P141	14 X 25 X 1	14.0	24
600700101	0810101	P101	16 X 20 X 1	13.0	24
600700102	0810102	P102	16 X 25 X 1	16.0	24
600700103	0810103	P103	20 X 20 X 1	16.0	24
600700104	0810104	P104	20 X 25 X 1	19.0	24
600700105	0810105	P105	24 X 24 X 1	24.0	24
600700132	0810132	P132	20 X 30 X 1	30.0	24
600700201	0810201	P201	16 X 20 X 2	13.0	12
600700202	0810202	P202	16 X 25 X 2	16.0	12
600700203	0810203	P203	20 X 2 0X 2	16.0	12
600700204	0810204	P204	20 X 25 X 2	16.0	12
600700205	0810205	P205	24 X 24 X 2	24.0	12

# FOAM



## Washable Foam Filter Media Pads

- \* Washable for repeated use
- \* Withstands wide temperature extremes
- \* Initial resistance @ 300 FPM 1/4" - .05", 1/2" - .12" & 1" - .16"
- \* Arrestance 1/4" - 55%, 1/2" - 60% & 1" - 65%
- \* Recommended final resistance 1/4" - .50", 1/2" - .50" & 1" - .50"

Brauer P/N	Item #	Model #	Nominal Size	Weight	Carton Qty
600602601	0840001	F2601	16 X 20 X 1/2	3.0	24
600602602	0840002	F2602	16 X 25 X 1/2	4.0	24
600602603	0840003	F2603	20 X 20 X 1/2	4.0	24
600602604	0840004	F2604	20 X 25 X 1/2	5.0	24
600602605	0840005	F2605	24 X 24 X 1/2	6.0	24
600602701	0840101	F2701	16 X 20 X 1	5.0	24
600602702	0840102	F2702	16 X 25 X 1	6.0	24
600602703	0840103	F2703	20 X 20 X 1	6.0	24
600602704	0840104	F2704	20 X 25 X 1	7.0	24
600602705	0840105	F2705	24 X 24 X 1	8.0	24

## Washable Foam Filter Media Rolls

- \* Washable for repeated use
- \* Withstands wide temperature extremes
- \* Initial resistance @ 300 FPM 1/4" - .05", 1/2" - .12" & 1" - .16"
- \* Arrestance 1/4" - 55%, 1/2" - 60% & 1" - 65%
- \* Recommended final resistance 1/4" - .50", 1/2" - .50" & 1" - .50"



Brauer P/N	Item #	Model #	Nominal Size	Weight	Carton Qty
60060250	1030125	AFS-25-1	24" X 10' X 1/4"	1.0	1
60060251	1030224	AFS-25-1B	24" X 25' X 1/4"	2.0	1
60060252	1030128	AFS-25-2	36" X 10' X 1/4"	2.0	1
60060253	1030236	AFS-25-2B	36" X 25' X 1/4"	3.0	1
60260500	1030126	AFS-26-1	24" X 10' X 1/2"	3.0	1
60260501	1030324	AFS-26-1B	24" X 25" X 1/2"	4.0	1
60260502	1030129	AFS-26-2	36" X 10' X 1/2"	3.0	1
60260503	1030127	AFS-27-1	24" X 10' X 1"	5.0	1

# SLIP-ON SERVICE ROLLS

Type SS polyester and spunbonded. For use in fan coil units, package air conditioning units in hotels, commercial buildings, and hospitals.



- \* Goes on replaceable, rust resistant, 9-gauge internal steel wire
- \*MERV 5
- \*Initial pressure drop .30" w.g. @ 400 FPM
- \*Dust holding capacity 105 grams @ 1.5" w.g
- \*Arrestance efficiency is 85%



Brauer P/N	Item #	Model #	Nominal Size	Carton Qty
6029507135	115-731-007	SS-007	7" X 135'	1
6029508135	115-731-008	SS-008	8" X 135'	1
6029509135	115-731-009	SS-009	9" X 135'	1
6029510135	115-731-010	SS-010	10" X 135'	1
6029511135	115-731-011	SS-011	11" X 135'	1
6029512135	115-731-012	SS-012	12" X 135'	1
6029513135	115-731-013	SS-013	13" X 135'	1
6029514135	115-731-014	SS-014	14" X 135'	1
6029515135	115-731-015	SS-015	15" X 135'	1
6029516135	115-731-016	SS-016	16" X 135'	1
6029520135	115-731-020	SS-020	20" X 135'	1
6029525135	115-731-025	SS-025	25" X 135'	1

## THRIFT-AIRE ALUMINUM FILTER

Construction: Frame shall be formed aluminum channel, mitered and secured at one corner by rivets. Filtering media shall consist of multiple layers of aluminum, expanded through specified feeds to assure maximum filtering and internal loading capabilities. Filters shall retain 290 grams of dust per 2.25 sq. ft. (20x20 filter). Resistance when clean is 0.05 w.g. at 350 F.P.M. air velocity. Maximum resistance at capacity is 0.335 w.g. Filtering element shall be processed from sheet aluminum, commercially known as 3003-H22, .025 in thickness expanded with .020 strand. Frame shall be made from sheet aluminum 3003-H14, .025 thickness. Max temperature is 240 degrees F.

Brauer P/N	Item #	Nominal Size	Carton Qty
600011190	TA16201N	16 X 20 X 1	12
600011220	TA16251N	16 X 25 X 1	12
600011260	TA20201N	20 X 20 X 1	12
600011280	TA20251N	20 X 25 X 1	12
600011180	TA24241N	24 X 24 X 1	12
600012110	TA10202N	10 X 20 X 2	12
600012120	TA12242N	12 X 24 X 2	12
600012190	TA16202N	16 X 20 X 2	12
600012220	TA16252N	16 X 25 X 2	12
600012260	TA20202N	20 X 20 X 2	12
600012280	TA20252N	20 X 25 X 2	12
600012370	TA24242N	24 X 24 X 2	12

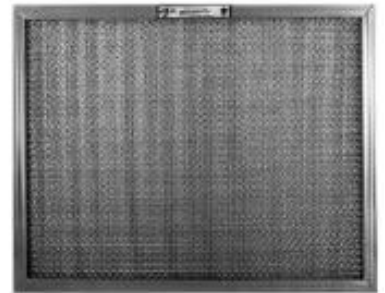

### ALSO AVAILABLE:

- \*Lifetime Filter
- \*Heavy-Duty Filter
- \*430 Stainless Steel Filter
- \*Mist Eliminator Filter (Galvanized Steel)
- \*Mist Eliminator Filter(Aluminum)
- \*Mist Eliminator Filter (304 Stainless Steel)
- \*Perm-A-Foam Filter
- \*Fire Guard "G"
- \*Fire RB-1 "A"
- \*Thrifty Flame Stop "G" & "S"
- \*Bonded "A" Filter
- \*Perm-A-Steel Filter
- \*Steel Smith Filter
- \*304 Stainless Steel Filter
- \*Electrostatic Filters
- \*Foam Filter
- \*Fire Patrol "G"
- \*Fire RB-1 "G"
- \*Fire Patrol "A"
- \*Fire Patrol 430 "S"
- \*Fire Patrol 304 "S"



## P-SERIES PADS

Polyester media roll, light Tack on the air leaving side

Brauer P/N	Item #	Nominal Size	Weight	Carton Qty
602010990	P50-10	12 X 24 X 1/2	3.2	25
602201120	P50-01	16 X 20 X 1/2	3.8	25
602201130	P50-02	16 X 25 X 1/2	4.0	25
602201150	P50-03	20 X 20 X 1/2	4.0	25
602201170	P50-04	20 X 25 X 1/2	4.4	25
602201180	P50-05	24 X 24 X 1/2	5.0	25
Brauer P/N	Item #	Nominal Size	Weight	Carton Qty
602201185	P100-10	12 X 24 X 1	4.3	25
602201191	P100-01	16 X 20 X 1	5.0	25
602201221	P100-02	16 X 25 X 1	6.0	25
602201261	P100-03	20 X 20 X 1	6.0	25
602201281	P100-04	20 X 25 X 1	6.6	25
602201371	P100-05	24 X 24 X 1	7.0	25
Brauer P/N	Item #	Nominal Size	Weight	Carton Qty
602202120	P200-10	12 X 24 X 2	4.3	20
602202190	P200-01	16 X 20 X 2	5.0	20
602202220	P200-02	16 X 25 X 2	6.0	20
602202260	P200-03	20 X 20 X 2	6.0	20
602202280	P200-04	20 X 25 X 2	6.6	20
602202370	P200-05	24 X 24 X 2	7.0	20
Brauer P/N	Item #	Nominal Size	Weight	Carton Qty
602202420	P200S-10	12 X 24 X 2	4.3	20
602202490	P200S-01	16 X 20 X 2	5.0	20
602202420	P200S-02	16 X 25 X 2	6.0	20
602202460	P200S-03	20 X 20 X 2	6.0	20
602202480	P200S-04	20 X 25 X 2	6.6	20
602202470	P200S-05	24 X 24 X 2	7.0	20

## POLYESTER MEDIA ROLL

- VL-05PST
- \* 1/2" Loft
- \* 4 oz/sy
- \* Blue/white
- \* Tacky



Brauer P/N	Item #	Nominal Size	SQ. FT.	Weight
6020108135	12178	8" X 135'	90.0	6
6020110135	12179	10" X 135'	113.0	6
6020112135	12180	12" X 135'	135.0	8
6020116135	12181	16" X 135'	180.0	9
6020120135	12182	20" X 135'	225.0	11
6020124135	12183	24" X 135'	270.0	13
6020125135	12184	25" X 135'	281.0	13
6020130135	12185	30" X 135'	338.0	15
6020136135	12186	36" X 135'	405.0	18
6020140135	12187	40" X 135'	450.0	20
6020148135	12188	48" X 135'	540.0	22
6020150135	12189	50" X 135'	563.0	26
6020160135	12190	60" X 135'	675.0	30
6020172135	12191	72" X 135'	810.0	26
6020184135	12192	84" X 135'	945.0	40



VL-09PST  
 \* 1" Loft  
 \* 6 oz/sy  
 \* Blue/white  
 \* Tack

Brauer P/N	Item #	Nominal Size	SQ. FT.	Weight
602011081	12210	8" X 90'	60	6
602011101	12211	10" X 90'	75	6
602011121	12212	12" X 90'	90	7
602011161	12213	16" X 90'	120	9
602011201	12214	20" X 90'	150	11
602011241	12215	24" X 90'	180	13
602011251	12216	25" X 90'	188	13
602011301	12217	30" X 90'	225	15
602011361	12218	36" X 90'	270	17
602011401	12219	40" X 90'	300	20
602011481	12220	48" X 90'	360	22
602011501	12221	50" X 90'	375	26
602012000	12222	60" X 90'	450	30
602011721	12223	72" X 90'	540	34
602011841	12224	84" X 90'	630	39

VL-19PST  
 \* 1-1/2" Loft  
 \* 11 oz/ sy  
 \* Blue /white  
 \* Tack



Brauer P/N	Item #	Nominal Size	SQ. FT.	Weight
6020120860	12257	8" X 45'	30	3
6020121060	12258	10" X 45'	38	4
6020121260	12259	12" X 45'	45	5
6020121660	12260	16" X 45'	60	8
6020122060	12261	20" X 45'	75	8
6020122460	12262	24" X 45'	90	10
6020122560	12263	25" X 45'	94	10
6020123060	12264	30" X 45'	113	12
6020123660	12265	36" X 45'	135	14
6020124060	12266	40" X 45'	150	16
6020124860	12267	48" X 45'	180	17
6020125060	12268	50" X 45'	188	20
6020126060	12269	60" X 45'	225	24
6020127260	12270	72" X 45'	270	28
6020128460	12271	84" X 45'	315	33



VL-OR1  
 \* 1" Loft  
 \* 11.25 oz/sy  
 \* Orange/white  
 \* Heavy dry tack



Brauer P/N	Item #	Nominal Size	SQ. FT.	Weight
602010890	78831	8" X 90'	60	6
602011090	78832	10" X 90'	75	6
602011290	78833	12" X 90'	90	7
602011690	78834	16" X 90'	120	9
602012090	78835	20" X 90'	150	11
602012490	78836	24" X 90'	180	13
602012590	78837	25" X 90'	188	13
602013090	78838	30" X 90'	225	15
602013690	78839	36" X 90'	270	17
602014090	78840	40" X 90'	300	20
602014890	78841	48" X 90'	360	22
602015090	78842	50" X 90'	375	26
602016090	78843	60" X 90'	450	30
602017290	78844	72" X 90'	540	34
602018490	78845	84" X 90'	630	39

VL-OR2

- \* 1-1/2" Loft
- \* 14.40 oz/sy
- \* Orange/white
- \* Heavy dry tack



Brauer P/N	Item #	Nominal Size	SQ. FT.	Weight
602010860	78846	8" X 60'	40	6
602011060	78847	10" X 60'	50	6
602011260	78848	12" X 60'	60	7
602011660	78849	16" X 60'	80	9
602012060	75943	20" X 60'	100	11
602012460	78850	24" X 60'	120	13
602012560	78851	25" X 60'	125	13
602013060	78852	30" X 60'	150	15
602013660	78853	36" X 60'	180	17
602014060	78854	40" X 60'	200	20
602014860	78855	48" X 60'	240	22
602015060	78856	50" X 60'	250	26
602016060	78857	60" X 60'	300	30
602017260	78858	72" X 60'	360	34
602018460	78859	84" X 60'	420	39

VL-10

- \* 1" High loft
- \* 7 oz/sy
- \* White
- \* Dry



Brauer P/N	Item #	Nominal Size	SQ. FT.	Weight
6020116985	16985	8" X 90'	60	4
6020116986	16986	10" X 90'	75	5
6020116987	16987	12" X 90'	90	6
6020116988	16988	16" X 90'	120	8
602012000	16989	20" X 90'	150	10
6020116990	16990	24" X 90'	180	12
6020116991	16991	25" X 90'	188	12
6020116992	16992	30" X 90'	225	14
6020116993	16993	36" X 90'	270	17
6020116994	16994	40" X 90'	300	19
6020116995	16995	48" X 90'	360	23
6020116996	16996	50" X 90'	375	24
6020116997	16997	60" X 90'	450	29
6020116998	16998	72" X 90'	540	35
6020178862	78862	84" X 90'	630	41

- VL-45
- \* 1-1/4" Loft
- \* 8.5 oz/sy
- \* 15/45 Dual denier
- \* White
- \* Dry
- \* Heat sealable



Brauer P/N	Item #	Nominal Size	SQ. FT.	Weight
6020112273	12273	8" X 45'	30	3
6020112274	12274	10" X 45'	38	3
6020112275	12275	12" X 45'	45	4
6020112276	12276	16" X 45'	60	6
6020112277	12277	20" X 45'	75	7
6020112278	12278	24" X 45'	90	8
6020112279	12279	25" X 45'	94	9
6020112280	12280	30" X 45'	113	10
6020112281	12281	36" X 45'	135	12
6020112282	12282	40" X 45'	150	14
6020112283	12283	48" X 45'	180	17
6020112284	12284	50" X 45'	188	17
6020112285	12285	60" X 45'	225	21
6020112286	12286	72" X 45'	270	25
6020112287	12287	84" X 45'	315	29

Rolls also available in antimicrobial

## AUTO ROLL

Type DSF automatic roll filter media, 1/2" thick x 65' long

System: Air Maze Roll-A-Maze

Brauer P/N	Item #	Model #	Filter Size	Actual Core Width	Weight
604012020	0922020	2AM-DSF	2	20-1/2	8.8
604012030	0922030	3AM-DSF	3	32-1/2	13.8
604012040	0922040	4AM-DSF	4	44-1/2	18.8
604012050	0922050	5AM-DSF	5	56-1/2	23.8
604012060	0922060	6AM-DSF	6	68-1/2	28.8



System: American Air Filter Roll-A-Matic

Brauer P/N	Item #	Model #	Filter Size	Actual Core Width	Weight
604018303	0920030	3AE-DSF	3	32-3/4	13.8
604018304	0920040	4AE-DSF	4	44-3/4	18.8
604018305	0920050	5AE-DSF	5	56-3/4	23.8
604018306	0920060	6AE-DSF	6	68-3/4	28.8
604018321	0920210	21AE-DSF	21	20-1/4	8.8
604018322	0920220	22AE-DSF	22	22-1/4	9.6
604018325	0920250	25AE-DSF	25	24-7/8	10.4
604018332	0920320	32AE-DSF	32	31-7/8	13.3
604018339	0920390	39AE-DSF	39	38-1/2	16.3
604018340	0920400	40AE-DSF	40	39-7/8	16.7

System: BLC and Airguard Ind. Automatic Roll Machine

Brauer P/N	Item #	Model #	Filter Size	Actual Core Width	Weight
604018100	0928100	10B-DSF	2	24-5/8	12.3
604018110	0928110	11B-DSF	3	34-5/8	15.2
604018120	0928120	12B-DSF	4	46-5/8	19.6
604018130	0928130	13B-DSF	5	58-5/8	25.1
604018140	0928140	14B-DSF	6	70-5/8	29.8
604018150	0928150	15B-DSF	7	38-5/8	40.0

System: Cambridge and/or ElectroAir

Brauer P/N	Item #	Model #	Filter Size	Actual Core Width	Weight
604011020	0921020	2CB-DSF	2	23-7/8	12.3
604011030	0921030	3CB-DSF	3	32-7/8	15.2
604011040	0921040	4CB-DSF	4	44-7/8	19.6
604011050	0921050	5CB-DSF	5	56-7/8	25.1
604011060	0921060	6CB-DSF	6	65-7/8	29.8
604011065	0921065	6HCB-DSF	6	68-7/8	28.8

System: Carrier Corp. Model 31NA Roll Filter

Brauer P/N	Item #	Model #	Filter Size	Actual Core Width	Weight
604014020	0924020	2CR-DSF	31NA-20	26-1/4	11.3
604014030	0924030	3CR-DSF	31NA-40	37-1/4	15.8
604014040	0924040	4CR-DSF	31NA-50	47-1/4	20.0
604014060	0924060	6CR-DSF	31NA-60	61-1/4	25.8
604014024	0924024	24CR-DSF	31NC-20	23-1/2	10.2
604014035	0924035	35CR-DSF	21NC-40	34-1/2	13.8
604014044	0924044	44CR-DSF	31NC-50	44.0	18.8
604014058	0924058	58CR-DSF	31NC-60	58.0	23.8
604014068	0924068	68CR-DSF	31NC-70	68.0	28.2

System: Continental Air Filter Conomanual & Conomatic

Brauer P/N	Item #	Model #	Filter Size	Actual Core Width	Weight
604015020	0925020	3C-DSF	2	9.2	9.2
604015030	0925030	3C-DSF	3	13.3	13.3
604015040	0925040	4C-DSF	4	18.3	18.3
604015050	0925050	5C-DSF	5	23.3	23.3
604015060	0925060	6C-DSF	6	28.3	28.3
604015360	0925360	36C-DSF	36	15.0	15.0

System: Camfil Roll Kleen Filters

Brauer P/N	Item #	Model #	Filter Size	Actual Core Width	Weight
604013030	0923030	3F-DSF	3	13.8	13.8
604013040	0923040	4F-DSF	4	18.8	18.8
604013050	0923050	5F-DSF	5	23.8	23.8
604013060	0923060	6F-DSF	6	28.8	28.8
604013120	0923120	12F-DSF	12	3.8	3.8
604013180	0923180	18F-DSF	18	6.3	6.3
604013200	0923200	20F-DSF	20,22	8.8	8.8
604013260	0923260	26F-DSF	26, 28	11.3	11.3
604013030	0923030	3F-DSF	30, 32	13.8	13.8
604013360	0923360	36F-DSF	36, 38	16.3	16.3
604013040	0923040	4F-DSF	40, 42	18.8	18.8
604013460	0923460	46F-DSF	46, 48	21.3	21.3
604013050	0923050	5F-DSF	50, 52	23.8	23.8

System: Trane Company Roll Filters

Brauer P/N	Item #	Model #	Filter Size	Actual Core Width	Weight
604016030	0926030	3T-DSF	RF3, RF7	8.3	8.3
604016060	0926060	6T-DSF	RF6, RF9	9.2	9.2
604016080	0926080	8T-DSF	RF8, RF10	13.3	13.3
604016120	0926120	12T-DSF	RF12, RF14	15.0	15.0
604016080	0926080	8T-DSF	RF17, RF21	13.3	13.3
604016120	0926120	12T-DSF	RF24, RF25	15.0	15.0
604016310	0926310	31T-DSF	RF31	19.2	19.2
604016350	0926350	35T-DSF	RF35	22.9	22.9
604016410	0926410	41T-DSF	RF41	25.0	25.0
604016500	0926500	50T-DSF	RF50	26.7	26.7
604016315	0926315	31T(2)-DSF	RF63	38.4	38.4
604016260	0926260	26T-DSF		10.8	10.8
604016380	0926380	38T-DSF		16.3	16.3
604016510	0926510	51T-DSF		21.3	21.3
604016610	0926610	61T-DSF		25.8	25.8

Also Available: CF, YTS, SHP, DMC, DL-1 AND DL-2



# Core Identification Guide

## Automatic Roll Filters

### Core Identification Guide

Shown here are photo's and brief descriptions of end views of various cores used on automatic roll filter machines. Airguard manufactures roll filter replacements for all machines, and this guide is offered for assistance in identifying the proper core when system identification is not possible through other means. All cores furnished are identical with those supplied by original equipment manufacturers.

\* Model No. indicates roll size and type. Media style is then designated with an additional suffix.

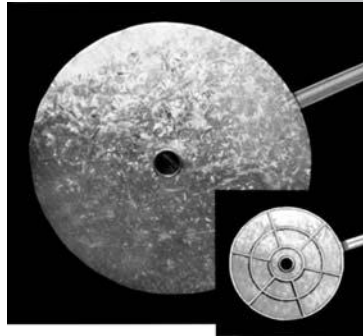

**Type AE Core** (to fit American Air Filter Roll-O-Matic). Core is 3/8" I.D. (1-1/8" O.D.) welded steel tube and metal discs. End plates of approximately 11" diameter are attached.

#### Sizes and Core Identification

Roll Width	Model No.*	Roll Width	Model No.*
32-3/4"	3AE	22-1/4"	22AE
44-3/4"	4AE	24-7/8"	25AE
56-3/4"	5AE	31-7/8"	32AE
68-3/4"	6AE	38-1/2"	39AE
20-1/4"	21AE	39-7/8"	40AE



**Type CR Core** (to fit Carrier Corporation Series 31NA Roll Filter). Core is formed from a 2-7/16" fiberboard tube. The tube contains a metal cup secured in each end and recessed to a depth of 1-1/2". The cup is stamped to form a 1-1/2" square opening.

#### Sizes and Core Identification

Series 31NA		Series 31NC	
Roll Width	Model No.*	Roll Width	Model No.*
26-1/4"	2CR	23-1/2"	24CR
37-1/4"	3CR	34-1/2"	35CR
47-1/4"	4CR	44"	44CR
61-1/4"	6CR	58"	58CR
		68"	68CR



**Type B Core** (to fit BLC Industries Automatic Roll Machine). Core is constructed from 1-1/2" diameter: EMT conduit, with 11" diameter end plates recessed in approximately 1-3/8" from end of core.

#### Sizes and Core Identification

Roll Width	Model No.*
24-5/8"	10B
34-5/8"	11B
46-5/8"	12B
58-5/8"	13B
	14B



**Type CB Core** (to fit Cambridge Autoroll). Core is 3/4" welded steel tube. No metal discs are used. (if desired, please specify).

#### Sizes and Core Identification

Roll Width	Model No.*
23-7/8"	2CB
32-7/8"	3CB
44-7/8"	4CB
56-7/8"	5CB
65-7/8"	6CB
70-5/8"	6HCB



**Type AM Core** (to fit Airmaze Roll-A-Maze). Core is formed from fiberboard tube with 1-7/8" I.D. tube has recessed cups secured in each end with a depth of 5/8". Cup is stamped to form a 1-1/2" x 3/4" rectangular slot.

#### Sizes and Core Identification

Roll Width	Model No.*
20-1/2"	2AM
32-1/2"	3AM
44-1/2"	4AM
56-1/2"	5AM
68-1/2"	6AM

# Core Identification Guide Cont.

## Automatic Roll Filters

**Type F Core** (to fit Farr Co. Roll Kleen Filters). Core is formed from\* 2-1/8" I.D. fiberboard tube using no drive pins, cups or discs.

Roll Width	Model No.*	Roll Width	Model No.*
33"	3F	15"	18F
45"	4F	21"	20F
57"	5F	27"	26F
69"	6F	39"	36F
9"	12F	51"	46F



**Type C Core** (to fit Continental Conomannual or Conomatic). Core is formed from 3-1/6" I.D. PVC tube. A drive pin is located 2-1/4" from one end of the tube only. No cups or discs are used.

Roll Width	Model No.*	Roll Width	Model No.*
21-7/8"	2C	55-7/8"	5C
31-7/8"	3C	67-7/8"	6C
43-7/8"	4C	35-7/8"	36C

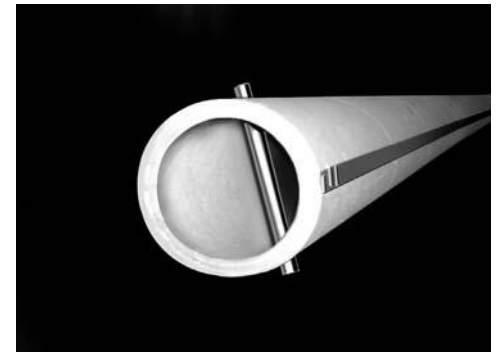

**Type T Core** (to fit Trane Company Roll Filter). Core is formed from 2-7/16" I.D. fiberboard tube. The tube contains a metal cup secured in each end recessed to a depth of 1-1/2" square.

Roll Width	Model No.*	Roll Width	Model No.*
19-3/8"	3T	59-3/8"	41T
21-3/8"	6T	63-3/8"	50T
31-3/8"	8T	25-3/4"	26T
35-3/8"	12T	38-3/4"	38T
45-3/8"	31T	50-1/4"	51T
54-3/8"	35T	61-3/4"	61T





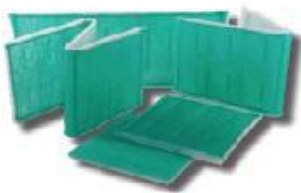

## POLYESTER PANELS AND LINKS

### MG200

Economical, 3-ply, UL Class 1 panel filter. For use in commercial buildings, hospitals, industrial plants, and paint spray booths. Green/white media, MERV 7, Initial pressure drop .36" w.g. @ 400 FPM, Dust holding capacity 243 grams @ 1.5" w.g. arrestance efficiency 89.76%, downstream tackifier and available in links.

Brauer P/N	Product Code	Model #	Filter Size	Carton Qty	Weight
602602202	132-1020-01	MG2-202	10 X 20	24	8
602602203	132-1224-01	MG2-203	12 X 24	24	9
602602204	132-1620-01	MG2-204	16 X 20	24	9
602602205	132-1625-01	MG2-205	16 X 25	24	12
60260203	132-2020-01	MG2-206	20 X 20	24	12
602602210	132-2024-01	MG2-210	20 X 24	24	14
602602207	132-2025-01	MG2-207	20 X 25	24	14
602602208	132-2424-01	MG2-208	24 X 24	24	15
602602209	132-2025-02	MG2-209	20 X 50	12	15

### MG300

All-purpose 3-ply panel filter. For use in commercial buildings, hospitals and industrial plants. White/white media, MERV 8, Initial pressure drop .28" w.g. @ 400 FPM, Dust holding capacity 268 grams @ 1.5" w.g. arrestance efficiency 88.79%, tackifier encapsulated between 2nd and 3rd layers and available in antimicrobial and links.



Brauer P/N	Product Code	Model #	Filter Size	Carton Qty	Weight
602603302	133-1020-01	MG3-302	10 X 20	24	8
602603303	133-1224-01	MG3-303	12 X 24	24	9
6026014201	133-1420-01	MG3	14 X 20	24	9
6026014251	133-1425-01	MG3	14 X 25	24	9
6026016201	133-1620-01	MG3-304	16 X 20	24	9
6026016251	133-1625-01	MG3-305	16 X 25	24	12
6026018241	133-1824-01	MG3	18 X 24	24	12
6026020201	133-2020-01	MG3-306	20 X 20	24	12
6026020241	133-2024-01	MG3-310	20 X 24	24	14
6026020251	133-2025-01	MG3-307	20 X 25	24	14
6026024241	133-2424-01	MG3-308	24 X 24	24	15
6026025251	133-2525-01	MG3	25 X 25	24	15
602603309	133-2025-02	MG3-309	20 X 50	12	15

### MG400

Heavy-duty 4-ply panel designed for applications requiring higher efficiency. For use in commercial buildings, hospitals, industrial plants, and paint spray booths. White/green media, MERV 11, Initial pressure drop .48" w.g. @ 400 FPM, Dust holding capacity 195 grams @ 1.5" w.g. arrestance efficiency 92.53%, tackifier downstream and available in antimicrobial and links.

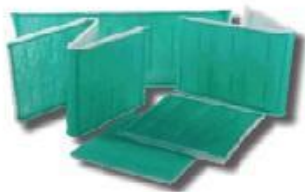

Brauer P/N	Product Code	Model #	Filter Size	Carton Qty	Weight
602604402	134-1020-01	MG4-402	10 X 20	24	8
602604403	134-1224-01	MG4-403	12 X 24	24	9
602604404	134-1620-01	MG4-404	16 X 20	24	9
602604405	134-1625-01	MG4-405	16 X 25	24	12
602604406	134-2020-01	MG4-406	20 X 20	24	12
602604410	134-2024-01	MG4-410	20 X 24	24	14
602604407	134-2025-01	MG4-407	20 X 25	24	14
602604408	134-2424-01	MG4-408	24 X 24	24	15
602604409	134-2025-02	MG4-409	20 X 50	12	15

### MG550

3-ply all-white antimicrobial tackified panel with heavy duty wire support. For use in commercial buildings, hospitals, industrial plants, and paint spray booths. White/white media, MERV 8, Initial pressure drop .33" w.g. @ 400 FPM, Dust holding capacity 245 grams @ 1.5" w.g. arrestance efficiency 89.67%, tackifier downstream and available in antimicrobial and links.



Brauer P/N	Product Code	Model #	Filter Size	Carton Qty	Weight
602605502	135-1020-01	MG5-502	10 X 20	24	8
602605503	135-1224-01	MG5-503	12 X 24	24	9
602605504	135-1620-01	MG5-504	16 X 20	24	9
602605505	135-1625-01	MG5-505	16 X 25	24	12
602605506	135-2020-01	MG5-506	20 X 20	24	12
602605510	135-2024-01	MG5-510	20 X 24	24	14
602605507	135-2025-01	MG5-507	20 X 25	24	14
602605508	135-2424-01	MG5-508	24 X 24	24	15
602605509	135-2025-02	MG5-509	20 X 50	12	15

Panels and links also available in antimicrobial

### BAG FILTERS

Clean-Pak high efficiency, extended surface pocket filters, synthetic media.

- \* High efficiency, meltblown synthetic media
- \* Polypropylene fabric ribbon separators
- \* Galvanized steel pocket retainers
- \* Rated velocity 500 FPM
- \* Sonic welded pocket construction
- \* Galvanized steel header
- \* Recommended final resistance 1.5" w.g.
- \* Maximum operating temperature 190 degree F



MERV 15, 90-95%, 0.40" w.g. @ 1968 CFM

Brauer P/N	Item #	Model #	Filter Size (HxWxD)	Actual Size (HxW)	Carton Qty	Number of Pockets	Weight
601100001	0570001	CP9-A-9-36	24 X 24 X 36	23-3/8 X 23-3/8	4	9	44.0
601100014	0570014	CP9-A-8-36	24 X 24 X 36	23-3/8 X 23-3/8	4	8	40.0
601100028	0570028	CP9-A-7-36	24 X 24 X 36	23-3/8 X 23-3/8	4	7	36.0
601100042	0570042	CP9-A-6-36	24 X 24 X 36	23-3/8 X 23-3/8	4	6	32.0
601100070	0570070	CP9-B-3-36	24 X 12 X 36	23-3/8 X 11-3/8	4	3	36.0
601100098	0570098	CP9-C-6-36	12 X 24 X 36	11-3/8 X 23-3/8	4	6	28.0
601100168	0570168	CP9-F-5-33	20 X 20 X 33	19-3/8 X 19-3/8	4	5	16.0



Brauer P/N	Item #	Model #	Filter Size (HxWxD)	Actual Size (HxW)	Carton Qty	Number of Pockets	Weight
601100182	0570182	CP9-A-10-32	24 X 24 X 32	23-3/8 X 23-3/8	4	10	40.0
601100196	0570196	CP9-B-5-32	24 X 12 X 32	23-3/8 X 11-3/8	4	5	40.0
601100378	0570378	CP9-A-10-29	24 X 24 X 29	23-3/8 X 23-3/8	4	10	38.0
601100238	0570238	CP9-A-8-29	24 X 24 X 29	23-3/8 X 23-3/8	4	8	36.0
601100266	0570266	CP9-A-6-29	24 X 24 X 29	23-3/8 X 23-3/8	4	6	30.0
601100280	0570280	CP9-B-4-29	24 X 12 X 29	23-3/8 X 11-3/8	4	4	40.0
601100294	0570294	CP9-B-3-29	24 X 12 X 29	23-3/8 X 11-3/8	4	3	29.3
601100308	0570308	CP9-C-6-29	12 X 24 X 29	11-3/8 X 23-3/8	4	6	26.6
601100336	0570336	CP9-D-5-29	24 X 20 X 29	23-3/8 X 19-3/8	4	5	18.6
601100364	0570364	CP9-E-6-29	20 X 24 X 29	19-3/8 X 23-3/8	4	6	30.0
601100420	0570420	CP9-A-10-25	24 X 24 X 25	23-3/8 X 23-3/8	4	10	32.0
601100434	0570434	CP9-B-5-25	24 X 12 X 25	23-3/8 X 11-3/8	4	5	32.0
601100462	0570462	CP9-A-10-22	24 X 24 X 22	23-3/8 X 23-3/8	4	10	34.0
601100490	0570490	CP9-A-8-22	24 X 24 X 22	23-3/8 X 23-3/8	4	8	16.0
601103300	0570518	CP9-A-6-22	24 X 24 X 22	23-3/8 X 23-3/8	4	6	28.0
601100532	0570532	CP9-B-5-22	24 X 12 X 22	23-3/8 X 11-3/8	4	5	36.0
601100546	0570546	CP9-B-4-22	24 X 12 X 22	23-3/8 X 11-3/8	4	4	32.0
601100560	0570560	CP9-B-3-22	24 X 12 X 22	23-3/8 X 11-3/8	4	3	30.6
601100574	0570574	CP9-C-6-22	12 X 24 X 22	11-3/8 X 23-3/8	4	6	22.6
601100602	0570602	CP9-D-7-22	24 X 20 X 22	23-3/8 X 19-3/8	4	7	24.0
601100616	0570616	CP9-D-5-22	24 X 20 X 22	23-3/8 X 19-3/8	4	5	17.3
601100658	0570658	CP9-F-5-22	20 X 20 X 22	19-3/8 X 19-3/8	4	5	18.6
601100672	0570672	CP9-A-9-18	24 X 24 X 18	23-3/8 X 23-3/8	4	9	28.0
6011035000	0570714	CP9-A-6-18	24 X 24 X 18	23-3/8 X 23-3/8	4	6	24.0
601100728	0570728	CP9-B-3-18	24 X 12 X 18	23-3/8 X 11-3/8	4	3	26.6
601100742	0570742	CP9-A-12-15	24 X 24 X 15	23-3/8 X 23-3/8	4	12	28.0
601100756	0570756	CP9-A-10-15	24 X 24 X 15	23-3/8 X 23-3/8	4	10	26.0
601100770	0570770	CP9-B-5-15	24 X 12 X 15	23-3/8 X 11-3/8	4	5	26.0
601100784	0570784	CP9-D-8-15	24 X 20 X 15	23-3/8 X 19-3/8	4	8	22.0
601100868	0570868	CP9-A-6-14	24 X 24 X 14	23-3/8 X 23-3/8	4	6	19.0

MERV 14, 80-85%, 0.38" w.g. @ 1968 CFM



Brauer P/N	Item #	Model #	Filter Size (HxWxD)	Actual Size (HxW)	Carton Qty	Number of Pockets	Weight
601102001	0572001	CP8-A-9-36	24 X 24 X 36	23-3/8 X 23-3/8	4	9	44.0
601102014	0572014	CP8-A-8-36	24 X 24 X 36	23-3/8 X 23-3/8	4	8	40.0
601102028	0572028	CP8-A-7-36	24 X 24 X 36	23-3/8 X 23-3/8	4	7	18.0
601102042	0572042	CP8-A-6-36	24 X 24 X 36	23-3/8 X 23-3/8	4	6	32.0
601102070	0572070	CP8-B-3-36	24 X 12 X 36	23-3/8 X 11-3/8	4	3	36.0
601102098	0572098	CP8-C-6-36	12 X 24 X 36	11-3/8 X 23-3/8	4	6	28.0
601102168	0572168	CP8-F-5-33	20 X 20 X 33	19-3/8 X 19-3/8	4	5	16.0
601102182	0572182	CP8-A-10-32	24 X 24 X 32	23-3/8 X 23-3/8	4	10	40.0
601102196	0572196	CP8-B-5-32	24 X 12 X 32	23-3/8 X 11-3/8	4	5	40.0
601102378	0572378	CP8-A-10-29	24 X 24 X 29	23-3/8 X 23-3/8	4	10	38.0



Brauer P/N	Item #	Model #	Filter Size (HxWxD)	Actual Size (HxW)	Carton Qty	Number of Pockets	Weight
601102238	0572238	CP8-A-8-29	24 X 24 X 29	23-3/8 X 23-3/8	4	8	35.0
601102266	0572266	CP8-A-6-29	24 X 24 X 29	23-3/8 X 23-3/8	4	6	30.0
601102280	0572280	CP8-B-4-29	24 X 12 X 29	23-3/8 X 11-3/8	4	4	40.0
601102294	0572294	CP8-B-3-29	24 X 12 X 29	23-3/8 X 11-3/8	4	3	29.3
601102308	0572308	CP8-C-6-29	12 X 24 X 29	11-3/8 X 23-3/8	4	6	26.6
601102336	0572336	CP8-D-5-29	24 X 20 X 29	23-3/8 X 19-3/8	4	5	18.6
601102364	0572364	CP8-E-6-29	20 X 24 X 29	19-3/8 X 23-3/8	4	6	30.0
601102420	0572420	CP8-A-10-25	24 X 24 X 25	23-3/8 X 23-3/8	4	10	32.0
601102434	0572434	CP8-B-5-25	24 X 12 X 25	23-3/8 X 11-3/8	4	5	32.0
601102462	0572462	CP8-A-10-22	24 X 24 X 22	23-3/8 X 23-3/8	4	10	34.0
601102490	0572490	CP8-A-8-22	24 X 24 X 22	23-3/8 X 23-3/8	4	8	16.0
601102900	0572518	CP8-A-6-22	24 X 24 X 22	23-3/8 X 23-3/8	4	6	28.0
601102532	0572532	CP8-B-5-22	24 X 12 X 22	23-3/8 X 11-3/8	4	5	36.0
601102546	0572546	CP8-B-4-22	24 X 12 X 22	23-3/8 X 11-3/8	4	4	32.0
601102560	0572560	CP8-B-3-22	24 X 12 X 22	23-3/8 X 11-3/8	4	3	30.6
601102574	0572574	CP8-C-6-22	12 X 24 X 22	11-3/8 X 23-3/8	4	6	22.6
601102602	0572602	CP8-D-7-22	24 X 20 X 22	23-3/8 X 19-3/8	4	7	24.0
601102616	0572616	CP8-D-5-22	24 X 20 X 22	23-3/8 X 19-3/8	4	5	17.3
601102658	0572658	CP8-F-5-22	20 X 20 X 22	19-3/8 X 19-3/8	4	5	18.6
601102672	0572672	CP8-A-9-18	24 X 24 X 18	23-3/8 X 23-3/8	4	9	28.0
601102714	0572714	CP8-A-6-18	24 X 24 X 18	23-3/8 X 23-3/8	4	6	24.0
601102728	0572728	CP8-B-3-18	24 X 12 X 18	23-3/8 X 11-3/8	4	3	26.6
601102742	0572742	CP8-A-12-15	24 X 24 X 15	23-3/8 X 23-3/8	4	12	28.0
601102756	0572756	CP8-A-10-15	24 X 24 X 15	23-3/8 X 23-3/8	4	10	26.0
601102770	0572770	CP8-B-5-15	24 X 12 X 15	23-3/8 X 11-3/8	4	5	44.0
601102784	0572784	CP8-D-8-15	24 X 20 X 15	23-3/8 X 19-3/8	4	8	11.0
601102868	0572868	CP8-A-6-14	24 X 24 X 14	23-3/8 X 23-3/8	4	6	19.0

MERV 12, 60-65%, 0.27" w.g @ 1968 CFM



Brauer P/N	Item #	Model #	Filter Size (HxWxD)	Actual Size (HxW)	Carton Qty	Number of Pockets	Weight
601104001	0574001	CP6-A-9-36	24 X 24 X 36	23-3/8 X 23-3/8	4	9	44.0
601104014	0574014	CP6-A-8-36	24 X 24 X 36	23-3/8 X 23-3/8	4	8	40.0
601104028	0574028	CP6-A-7-36	24 X 24 X 36	23-3/8 X 23-3/8	4	7	36.0
601104042	0574042	CP6-A-6-36	24 X 24 X 36	23-3/8 X 23-3/8	4	6	32.0
601104070	0574070	CP6-B-3-36	24 X 12 X 36	23-3/8 X 11-3/8	4	3	36.0
601104098	0574098	CP6-C-6-36	12 X 24 X 36	11-3/8 X 23-3/8	4	6	28.0
601104168	0574168	CP6-F-5-33	20 X 20 X 33	19-3/8 X 19-3/8	4	5	16.0
601104182	0574182	CP6-A-10-32	24 X 24 X 32	23-3/8 X 23-3/8	4	10	40.0
601104196	0574196	CP6-B-5-32	24 X 12 X 32	23-3/8 X 11-3/8	4	5	40.0
601104378	0574378	CP6-A-10-29	24 X 24 X 29	23-3/8 X 23-3/8	4	10	38.0
601104238	0574238	CP6-A-8-29	24 X 24 X 29	23-3/8 X 23-3/8	4	8	36.0
601104266	0574266	CP6-A-6-29	24 X 24 X 29	23-3/8 X 23-3/8	4	6	30.0
601104280	0574280	CP6-B-4-29	24 X 12 X 29	23-3/8 X 11-3/8	4	4	40.0
601104294	0574294	CP6-B-3-29	24 X 12 X 29	23-3/8 X 11-3/8	4	3	29.3
601104308	0574308	CP6-C-6-29	12 X 24 X 29	11-3/8 X 23-3/8	4	6	26.6
601104336	0574336	CP6-D-5-29	24 X 20 X 29	23-3/8 X 19-3/8	4	5	18.6
601104364	0574364	CP6-E-6-29	20 X 24 X 29	19-3/8 X 23-3/8	4	6	30.0
601104420	0574420	CP6-A-10-25	24 X 24 X 25	23-3/8 X 23-3/8	4	10	32.0
601104434	0574434	CP6-B-5-25	24 X 12 X 25	23-3/8 X 11-3/8	4	5	32.0



Brauer P/N	Item #	Model #	Filter Size (HxWxD)	Actual Size (HxW)	Carton Qty	Number of Pockets	Weight
601104462	0574462	CP6-A-10-22	24 X 24 X 22	23-3/8 X 23-3/8	4	10	34.0
601104490	0574490	CP6-A-8-22	24 X 24 X 22	23-3/8 X 23-3/8	4	8	16.0
6011014000	0574518	CP6-A-6-22	24 X 24 X 22	23-3/8 X 23-3/8	4	6	28.0
601104532	0574532	CP6-B-5-22	24 X 12 X 22	23-3/8 X 11-3/8	4	5	36.0
601104546	0574546	CP6-B-4-22	24 X 12 X 22	23-3/8 X 11-3/8	4	4	32.0
601104560	0574560	CP6-B-3-22	24 X 12 X 22	23-3/8 X 11-3/8	4	3	30.7
601104574	0574574	CP6-C-6-22	12 X 24 X 22	11-3/8 X 23-3/8	4	6	22.6
601104602	0574602	CP6-D-7-22	24 X 20 X 22	23-3/8 X 19-3/8	4	7	24.0
601104616	0574616	CP6-D-5-22	24 X 20 X 22	23-3/8 X 19-3/8	4	5	17.3
601104658	0574658	CP6-F-5-22	20 X 20 X 22	19-3/8 X 19-3/8	4	5	18.6
601104672	0574672	CP6-A-9-18	24 X 24 X 18	23-3/8 X 23-3/8	4	9	28.0
601104714	0574714	CP6-A-6-18	24 X 24 X 18	23-3/8 X 23-3/8	4	6	24.0
601104728	0574728	CP6-B-3-18	24 X 12 X 18	23-3/8 X 11-3/8	4	3	26.6
601104756	0574756	CP6-A-10-15	24 X 24 X 15	23-3/8 X 23-3/8	4	10	26.0
601104770	0574770	CP6-B-5-15	24 X 12 X 15	23-3/8 X 11-3/8	4	5	26.0
601104784	0574784	CP6-D-8-15	24 X 20 X 15	23-3/8 X 19-3/8	4	8	22.0
601104868	0574868	CP6-A-6-14	24 X 24 X 14	23-3/8 X 23-3/8	4	6	19.0

MERV 11, 50-55%, 0.25" w.g. @ 1968 CFM



Brauer P/N	Item #	Model #	Filter Size (HxWxD)	Actual Size (HxW)	Carton Qty	Number of Pockets	Weight
601106238	0576238	CP5-A-8-29	24 X 24 X 29	23-3/8 X 23-3/8	4	8	36.0
601106266	0576266	CP5-A-6-29	24 X 24 X 29	23-3/8 X 23-3/8	4	6	30.0
601106280	0576280	CP5-B-4-29	24 X 12 X 29	23-3/8 X 11-3/8	4	4	40.0
601106294	0576294	CP5-B-3-29	24 X 12 X 29	23-3/8 X 11-3/8	4	3	29.3
601106308	0576308	CP5-C-6-29	12 X 24 X 29	11-3/8 X 23-3/8	4	6	26.6
601106490	0576490	CP5-A-8-22	24 X 24 X 22	23-3/8 X 23-3/8	4	8	16.0
601106518	0576518	CP5-A-6-22	24 X 24 X 22	23-3/8 X 23-3/8	4	6	28.0
601106546	0576546	CP5-B-4-22	24 X 12 X 22	23-3/8 X 11-3/8	4	4	32.0
601106560	0576560	CP5-B-3-22	24 X 12 X 22	23-3/8 X 11-3/8	4	3	30.6
601106574	0576574	CP5-C-6-22	12 X 24 X 22	11-3/8 X 23-3/8	4	6	32.0
601101000	0576798	CP5-A-6-21	24 X 24 X 21	23-3/8 X 23-3/8	4	6	17.0
601106980	0576980	CP5-B-3-21	24 X 12 X 21	23-3/8 X 11-3/8	4	3	26.6
601106944	0576944	CP5-D-5-21	24 X 20 X 21	23-3/8 X 19-3/8	4	5	13.3
601107008	0577008	CP5-F-5-21	20 X 20 X 21	19-3/8 X 19-3/8	4	5	10.0
601106672	0576672	CP5-A-9-18	24 X 24 X 18	23-3/8 X 23-3/8	4	9	28.0
601106714	0576714	CP5-A-6-18	24 X 24 X 18	23-3/8 X 23-3/8	4	6	24.0
601106728	0576728	CP5-B-3-18	24 X 12 X 18	23-3/8 X 11-3/8	4	3	26.6
601106756	0576756	CP5-A-10-15	24 X 24 X 15	23-3/8 X 23-3/8	4	10	28.0
601106770	0576770	CP5-B-5-15	24 X 12 X 15	23-3/8 X 11-3/8	4	5	32.0
601100900	0576868	CP5-A-6-14	24 X 24 X 14	23-3/8 X 23-3/8	4	6	19.0
601106882	0576882	CP5-B-3-14	24 X 12 X 14	23-3/8 X 11-3/8	4	3	19.0
601106812	0576812	CP5-A-6-10	24 X 24 X 10	23-3/8 X 23-3/8	4	6	21.0
601106826	0576826	CP5-B-3-10	24 X 12 X 10	23-3/8 X 11-3/8	4	3	29.3
601106840	0576840	CP5-D-5-10	24 X 20 X 10	23-3/8 X 19-3/8	4	5	14.0
601106854	0576854	CP5-F-5-10	20 X 20 X 10	19-3/8 X 19-3/8	4	5	10.0

A variety of bag options available  
Bags also available in antimicrobial

# FINAL FILTERS

## Advantage

- \* 2" Mini-pleat design provides higher efficiency and dust holding
- \* Optimal air flow ensures proper ventilation of occupied spaces
- \* Durable plastic frame
- \* No metal components; completely incinerable
- \* Available with side and up/downstream gasketing
- \* MERV 16/14A in accordance with ASHRAE Test Method 52.2 - 2012, Including Appendix J



## Legacy

- \* Unique channel flow molded media
- \* 4" is MERV 11 and 12" is MERV 11 & 15
- \* Very low resistance
- \* High dust holding capacity
- \* All plastic construction
- \* Light weight
- \* Lower energy cost
- \* MERV 14 and 15 models can earn points in support of registered LEED project certification



## Variflow HT

- \* For High Temperature Applications
- \* High efficiency microglass paper media
- \* Completely rigid, metal box construction
- \* Single header construction (standard), double header (optional)
- \* Cross braces and faceguards on both sides
- \* 6" and 12" depths available
- \* 24 gauge aluminized steel cell sides
- \* High temperature glass wrap sealant
- \* Three temperature ranges - 500°F, 750°F, 900°F
- \* Three efficiencies - 90-95%, 80-85%, 60-65%

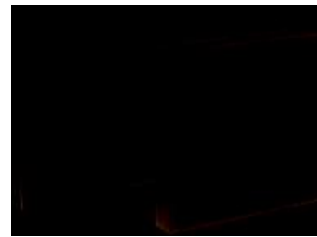

## Legacy LoadTech

- \* 4", MERV 14
- \* Holds 2X more dust with 100% synthetic, exclusive, blue media with our LoadTech Embossed Design
- \* Longer filter life and fewer filter change-outs with higher dust holding capacity
- \* 12" filter performance in a 4" filter
- \* Cost savings – reduced energy costs with low pressure drop and low energy consumption
- \* Simplified handling and easy installation – plus reduced storage space, less weight and lower shipping costs
- \* Completely incinerable with high impact plastic frame
- \* Earn points toward LEED Certification



## Variflow

- \* Ultrafine microglass paper media
- \* Moisture resistant construction
- \* Single header, double header, no header models
- \* Metal and wood cell sides
- \* 6" and 12" depths available
- \* Corrugated aluminum separators
- \* Three efficiencies - 90-95%, 80-85%, 60-65%

## Variflow SC

- \* Less media than the standard Variflow
- \* Ultrafine microglass paper media
- \* Moisture resistant construction
- \* Single header, double header, no header models
- \* Metal and wood cell sides
- \* 6" and 12" depths available
- \* Corrugated aluminum separators
- \* Three efficiencies - 90-95%, 80-85%, 60-65%





### Variflow Compact Series

- \* Ultrafine microglass paper media
- \* Aluminized steel cell sides
- \* Box construction - No header
- \* 2" and 4" depths available
- \* Corrugated aluminum separators
- \* High temperature operation up to 750°F
- \* Three efficiencies - 90-95%, 80-85%, 60-65%



### Variflow II-M

- \* Ultrafine microglass paper media
- \* Aluminized steel cell sides
- \* Box construction - No header
- \* 2" and 4" depths available
- \* Corrugated aluminum separators
- \* High temperature operation up to 750°F
- \* Three efficiencies - 90-95%, 80-85%, 60-65%

### Variflow II-MC

- \* Galvanized steel cell sides
- \* 13/16" header on air entering side
- \* Skip bead, mini-pleat adhesive separators
- \* For side access applications
- \* 4" depth available
- \* Two efficiencies - 90-95%, 60-65%



### V-Force

- \* All plastic construction
- \* 100% synthetic media
- \* Moisture and chemical resistant
- \* Fully incinerable
- \* Low resistance
- \* Three efficiencies - MERV 14, MERV 13, MERV 11

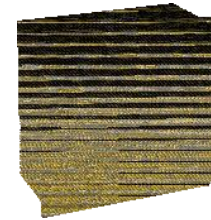

### Vari-Pak

- \* Ultrafine high loft microglass media
- \* Pleated construction with pleat stabilizers (fingers) on both sides
- \* Galvanized steel cell sides
- \* Box construction (no header) and header models
- \* 6" and 12" depths available
- \* Four efficiencies - MERV 14, MERV 13, MERV 11, MERV 10



### Vari-Pak GT

- \* For Turbine Intake Applications
- \* High loft fiberglass or synthetic media
- \* Expanded metal pleat support
- \* Pleat support stabilizers on both sides
- \* Three efficiencies - MERV 14, MERV 13, MERV 11

### Vari-Pak Model S

- \* Dual layer microfine synthetic media
- \* Pleated construction with pleat stabilizers (fingers) on both sides
- \* Galvanized steel cell sides
- \* Box construction (no header) and header models
- \* 6" and 12" depths available
- \* Four efficiencies - MERV 14, MERV 13, MERV 11, MERV 10



### **Duraflow**

- \* For Turbine Intake Applications
- \* Ultrafine microglass paper media
- \* Corrugated aluminum separators
- \* Galvanized steel construction
- \* Faceguard on both sides
- \* Two efficiencies – MERV 14, MERV 11



### **Vari+Plus VP**

- \* Suitable for HVAC or Turbine Intake Applications
- \* All plastic construction
- \* Revolutionary, exclusive, DURA-TUFF™ synthetic media
- \* Fully incinerable
- \* V-bank assembly of mini-pleat media packs
- \* No rivets, screws or faceguards
- \* Two efficiencies - MERV 15, MERV 13
- \* Also available with Microglass media



### **Vari+Plus MC**

- \* High efficiency microglass paper media
- \* Completely rigid design
- \* 24 gauge galvanized steel cell sides
- \* Mini-pleat packs with high media area - up to 300% more media
- \* Moisture resistant
- \* Pre-punched holes accept standard 12" spring clips
- \* Four efficiencies – MERV 16, MERV 14, MERV 13, MERV 11



### **Vari+Plus**

- \* Ultrafine microglass paper media
- \* Moisture resistant construction
- \* Mini-pleat adhesive bead separators
- \* V-bank assembly of mini-pleat media packs
- \* Large media area, low resistance
- \* Five efficiencies – MERV 16 DOP, MERV 16, MERV 14, MERV 13, MERV 11

### **Vari+Plus GT**

- \* For Turbine Intake Applications
- \* Ultrafine microglass paper media
- \* Mini-pleat adhesive bead separators
- \* V-bank assembly of mini-pleat media packs
- \* Two efficiencies – MERV 14, MERV 11
- \* Available with Vari-Pad direct mount pocket style prefilter



### **Vari-Pad**

- \* Mounts directly onto Airguard Vari+Plus GT high efficiency barrier filters
- \* Installed in the reverse flow orientation
- \* Extends barrier filter life
- \* Space saving design

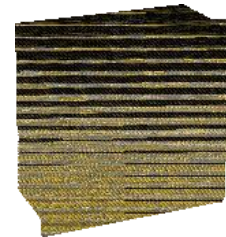

### **Bio-Pure Rigid Cell Box**

- \* Dual layer microfine synthetic media
- \* Pleated media design with pleat stabilizers on both sides
- \* Two efficiencies – MERV 14, MERV 13





### Bio-Pure Rigid Cell Supported Pleat

- \* Ultrafine microglass paper media
- \* MERV 16 efficiency
- \* Select from two styles of construction:
  - \* Corrugated aluminum separators
  - \* Continuous bead mini-pleat adhesive separators (V-bank media packs)

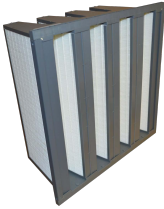

### DuraMax 4vs-16 Minipleat Filter

The DuraMAX 4vS-16 is a rigid, extended surface air filter engineered to provide maximum performance and prolonged filter lifecycles.

The rugged composition of the synthetic media makes the DuraMAX 4vS-16 an ideal choice for high velocity or high moisture systems, such as Gas Turbine Air Intakes.

- MERV 16 performance rating
- All-plastic frame construction
- Low resistance to airflow
- Excellent dust holding capacity
- 200 sq. ft of media in a 24"x24"x12" frame

The DuraMAX 4vS-16 is designed to meet the wide range of requirements found in today's position of complex air filtration systems. The 4vS-16 is constructed with a durable all-plastic frame that can be completely incinerated. The DuraMAX 4vS-16 can be reverse-installed in applications with space limitations.



### DuraMax 2v High Efficiency Minipleat Filter

The DuraMAX 2v is an extended surface air filter engineered to provide maximum performance and prolonged filter lifecycles in office buildings, hospitals, paint booths and all types of commercial and industrial HVAC applications. The DuraMAX 2v is completely incinerable after use.

What makes the DuraMAX 2v unique and different? The new 2v design offers all the benefits of our other high performance minipleat filters, but contains approximately 110 ft of filter media. The reduced media area makes the 2v model an economical alternative in applications where a minipleat filter is desired but initial purchase price is of utmost concern.

### Vari-Shield

- \* Combined pre-filter and coalescer
- \* Increased turbine output and reduced energy cost
- \* Very low resistance to airflow – 0.24" w.g. at 2,520 CFM
- \* High dust holding capacity
- \* Long filter life – fewer change-outs and less downtime
- \* Proprietary, patented E-pleat technology
- \* Lightweight construction
- \* 100% moisture resistant media
- \* Fully incinerable (no metal components)



### DuraMax 4V & 4VS Style Minipleat Filter

The DuraMAX is a rigid, extended surface air filter, engineered to provide maximum performance and prolonged filter life cycles, even in the most difficult environments. The durable, rugged, construction of the DuraMAX make it the filter of choice in filtration systems with high velocities or variable air volumes. DuraMAX Filters are constructed with a 100% plastic frame and are completely incinerable.

DuraMAX provides an unequalled combination of low pressure drop and high efficiency through the use of our unique minipleat design. This high capacity minipleat design allows a nominal 24x24x12 filter to incorporate 194 square feet of filter media. This increased extension of the media surface area insures low pressure drop, and low resistance to airflow means lower energy costs to the user.

Another benefit of the increased media area is extremely high Dust Holding Capacity, which significantly prolongs the service life of the filter. Fewer filter changes translate into substantially reduced maintenance and disposal costs.

The DuraMAX 4V are available in five ASHRAE efficiencies - 65, 75, 85, 95 and 98%.

The DuraMAX 4VS is available in 98%.

These filters are offered in three standard sizes - 24x24x12, 20x24x12 and 12x24x12. Single or double header configurations are available.



### Maxi-Cell Extended Surface Filter For High Velocity Applications

The Koch Maxi-Cell is a high efficiency, extended surface air filter designed for use in gas turbines and other applications where higher-than-normal airflow velocities exist. A step up from the Multi-Cell, the Maxi-Cell is constructed with faceguards on both sides of the filter and includes other features which make the Maxi-Cell a superior filter in any application where extreme conditions require additional filter strength and reliability.



### MicroMax Minipleat Filter

The Koch MicroMAX is an extended surface minipleat filter designed for use in a wide variety of air filtration systems. The MicroMAX offers a unique combination of high efficiency and low pressure drop making it the ideal filter for use in any standard HVAC system. The added advantages of its compact 4" depth and lightweight-yet-rigid construction also give the MicroMAX unsurpassed capability to perform in more specialized and difficult applications. MicroMAX Filters are available with standard beverage board frames or with galvanized steel frame. Steel framed MicroMAX filters are available with no header or with a single upstream header.

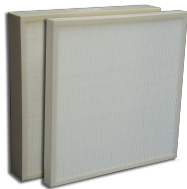

### MicroMax Edge Minipleat Filter

The MicroMAX EDGE™ is an all synthetic, durable minipleat panel filter that offers an incredible amount of media area compared to other filters of the same size. The increased media area and high dust holding capacity translate into fewer filter changes. Additionally, the MicroMAX EDGE™ design allows for lower energy costs as pressure drops remain low for longer periods. The high mechanical efficiency translates into a better level of indoor air quality.

#### All-Plastic Compact Design

The MicroMAX EDGE™ is manufactured in a 4" deep, durable plastic frame designed to replace almost any 12" competitive high efficiency filter. The lightweight all-plastic frame installs easily into side-access housings or front-load holding frames and is an ideal choice to replace bag filters and other heavier box-style rigid filters. The lightweight, compact design also helps lower shipping costs and the need for excess inventory space. It is also a preferred choice in applications where incineration is the desired means of disposal.

#### Nano Fiber Media

The MicroMAX EDGE™ features synthetic microfiber filter media with a 3 dimensional, progressive design for optimum dust holding capacities and product strength. The MicroMAX EDGE™ contains nanofibers integrated into the fiber media, providing the ability to capture the smallest particles. These synthetic fibers are produced in a solvent free, melt-based and environmentally friendly process and do not contain any chemical binder. These fibers also offer the added benefit of being non-shedding.



### MicroMax PL6 High Efficiency Minipleat Filter

The MicroMAX PL6™ is an extended surface, mini-pleat air filter engineered to provide maximum performance and prolonged filter lifecycles in all types of commercial and industrial HVAC applications. The MicroMAX PL6 is manufactured in a 6" deep, durable plastic frame designed to replace almost any 12" competitive high efficiency filter. The lightweight all-plastic frame installs easily into side-access housings or front-load holding frames and is an ideal choice to replace bag filters and other heavier box-style rigid filters. The lightweight, compact design also helps lower shipping costs and the need for excess inventory space. It is also a preferred choice in applications where incineration is the desired means of disposal. The media used in MicroMAX PL6 mini-pleat filters is composed of micro-fiberglass paper, treated with a specially-formulated, water-repellent binder. This dual-density media combined with a mini-pleat design ensures full media utilization, which results in higher dust holding capacity and extended filter life in a compact configuration. The MicroMAX PL6 is also available with antimicrobial-treated media.



### Multi-Flo Extended Surface Rigid Filters

The Koch Multi-Flo is a rigid, extended surface air filter engineered to provide medium and high efficiency air filtration, and long filter life cycles. The Multi-Flo, because of its rigid, durable construction, is capable of operating in a wide variety of air handling systems, and is an excellent product for variable-air-volume (V.A.V.) applications where changes in airflow might render a non-rigid filter ineffective.

Multi-Flo Extended Surface Filters are available with two media choices, Synthetic or Microfiberglass.



### Multi-Cell Extended Surface Filter

The Koch Multi-Cell is a high efficiency, extended surface air filter designed for use in HVAC applications of all types. Rigid construction makes the Multi-Cell a superior filter in variable-air-volume (VAV) systems, or in any application where extreme conditions require additional filter strength and reliability.





### LC Rigid

#### High Efficiency Extended Surface Air Filter

The Koch LC Rigid Filter is a high efficiency, extended surface air filter designed for use in light-to-moderate commercial and industrial applications. The LC Rigid Filter is constructed with a sturdy steel external frame. The media pack, composed of graded density microfiberglass paper and safe-edge aluminum separators, contains slightly less media than the Koch Multi-Cell. This reduced media area makes the LC Rigid an ideal product for systems in which a rigid configuration is preferred, yet initial purchase price is of paramount concern. LC Rigid Filters are presently used in a wide range of application such as variable-air-volume (VAV) and high humidity environments. The filter is offered in three face sizes and two efficiency ranges (90-95% and 60-65%). Three header configurations are available, FM Single Header, SBM Double Header, and NHM No Header.



### Multi-Cell Compact Size

Multi-Cell CS Filters are rigid, extended surface panel filters designed to provide high efficiency filtration in a compact, space-saving 2" or 4" deep frame. Multi-Cell CS Filters can be used in any air filter application, and are especially useful for upgrading the efficiency of filtration systems which presently have limited room for expansion or modification and in high temperature applications. The compact 2" or 4" depth enables the user to upgrade from standard pleated filters or other 2" and 4" low efficiency filters with no modification of the frames or housings.



### Multi-Cell HT for High Temperature Applications

Multi-Cell HT filters are constructed with aluminized steel frames designed for operation in applications with temperatures ranging from 350° to 900°, and are ideal for use in paint ovens where high temperatures may cause galvanized steel to scale or flake. Each filter has aluminized steel faceguards on both sides to protect the media against damage in shipping, handling, and actual operation. Two standard sizes, 24x24x12 and 12x24x12, are available in two efficiencies, 90-95% and 60-65%. The media used in all HT filters is the same type used in standard Multi-Cells. The media pack (which consists of nonflammable glass fiber media and aluminum separators) is secured within the frame by a special sealant which contains no silicone or other component which may be harmful to the painting process.



### Multi-Test Replacement Cartridge

Multi-Test Filters are extended surface high efficiency air filters designed to fit the basket framework of the Farr HP\* without modification. MT Filters are collapsible replacement cartridges, and are available in four nominal efficiency ranges: 20-30%, 45-55%, 80-90%, 90-95%.

## SERVICE ROLLS

Filter Depth = 1"  
 Glass Weight = 12 grams  
 Adhesive Weight = None  
 Media Total Weight = 12 gram  
 Initial Resistance - 300 FPM = 0.10" W.G.  
 Final Resistance = 0.50" W.G.



Brauer P/N	Item #	Model #	Nominal Size	Carton Qty
60570241	5180116005	GR AFS-46-24	1" x 24" x 240"	1
60570281	518011600	GR AFS-46-28	1" x 28" x 240"	1
60570301	5180116006	GR AFS-46-30	1" x 30" x 240"	1
60570361	5180116001	GR AFS-46-36	1" x 36" x 240"	1
60570401	5180116007	GR AFS-46-40	1" x 40" x 240"	1
605702485	5180102570	GR AFS-24	1" x 24" x 85'	1
605703085	5180102571	GR AFS-30	1" x 30" x 85'	1
605703685	5180102572	GR AFS-36	1" x 36" x 85'	1

## HEPAs



### Micro Guard 99

- \* Ultrafine microglass paper media
- \* Wood and metal construction
- \* Gasket seal and gel seal models
- \* Wide variety of cell side configurations
- \* Corrugated aluminum separators
- \* Three efficiencies - 99.97%, 99.99%, 99.999% on .3 microns

### Micro Guard SC Series

- \* Same media and construction as Micro Guard 99, except fewer pleats, 99.97% efficiency

### Micro Guard O/M

- \* Specially designed for use as the final filter in oil mist collection equipment
- \* Ultrafine microglass paper media
- \* Galvanized, aluminum and fire retardant particle board construction
- \* 95% efficient on .3 micron particles



### Micro Guard 2000 Separator Style

- \* 500 fpm @ 1.35" W.G.
- \* Ultrafine microglass paper media
- \* Wood and metal construction
- \* Gasket seal and gel seal models
- \* Wide variety of cell side configurations
- \* Corrugated aluminum separators
- \* 500 fpm @ 1.35" W.G.
- \* Three efficiencies - 99.97%, 99.99%, 99.999% on .3 microns



### MicroPleat Mini-Pleat Style Filter

- \* Ultrafine microglass paper media
- \* Anodized extruded aluminum cell sides
- \* Gasket seal, gel seal and knife edge models
- \* Continuous bead mini-pleat adhesive separators
- \* Four efficiencies - 99.97%, 99.99%, and 99.999% on .3 microns; 99.9995% on .12 microns





### Micro-V 2000 Mini-Pleat Style

- \* 500 fpm @ 1.2" W.G.
- \* 99.97%, 99.99% efficiencies @ 500 fpm
- \* 99.999% efficiency @ 400 fpm

### Micro-V™ 2400 Mini-Pleat Style

- \* 600 fpm @ 1.36" W.G
- \* 99.97% efficiency

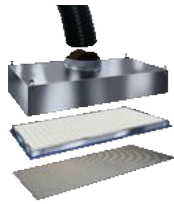

### Micro+Plus Bio-Tech

- \* Replaceable filter ceiling modules
- \* Low profile design
- \* Aluminum or stainless steel housing
- \* All welded construction



### BioMax CS

For Critical Applications - BioMAX™ CS is a compact size minipleat HEPA filter designed to meet the stringent requirements of today's clean room applications. BioMAX CS filters are engineered to provide the optimum combination of efficiency and airflow. They are used in a wide range of applications, including pharmaceutical facilities, hospitals, biotech laboratories and other environments where control and removal of airborne contaminants is of paramount importance in the protection of people, processes, and equipment.



### MicroPleat Disposable Ducted Ceiling Modules

- \* Anodized extruded aluminum construction
- \* 2' x 2' and 2' x 4' sizes
- \* Low profile design - 5" deep, fits into T-bar ceiling grid
- \* Fixed or adjustable diffuser/damper
- \* Three efficiencies - 99.99% and 99.999% on .3 microns; 99.9995% on .12 microns



### BioMax HEPA Filters

Koch Filter Corporation BioMAX HEPA Filters are designed to provide the highest level of filtration available for commercial and industrial applications. They are widely used in hospitals, clean rooms, pharmaceutical plants, and in hundreds of other systems where clean air is critical in the protection of people, processes and equipment. BioMAX HEPA Filters are constructed using the highest quality components available and are available in efficiencies of 99.97%, 99.99% and 99.999% on 0.3 micron particles. Standard construction BioMAX HEPA Filters are manufactured with galvanized steel cell sides (UL Class 1) or particle board cell sides (UL Class 2). Multiple cell side options are also available.



### BioMax HEPA Filters 95% DOP

Bridges the gap between ASHRAE and HEPA efficiencies.



**BioMax V2000**

High Capacity Mini-pleat HEPA Filters Neoprene Gasket Seal

- High Capacity design (300 sq.ft. of media in a 24x24x12" frame) enables the filter to operate at 500 FPM with initial resistance of 1.20" W.G.
- Standard models are furnished with the gasket on the downstream face of the filter. Gaskets can be placed upstream or on both sides of the filter upon request.
- Constructed with ten individual mini-pleat packs secured in a specially-designed sheet aluminum v-bank frame.



**BioMax HEPA Filters - High Temperature**

BioMAX High Temperature HEPA Filters are specially-designed for use in systems with above-normal operational temperatures. Several models are available.

**GAS PHASE FILTERS**



**Fresh Air**

- \* Combination media removes particulate plus gases and odors
- \* 100% synthetic pre-filter charged media
- MERV 7
- \* Activated carbon media containing 200 grams per square meter provides long lasting odor removal
- \* Self-supported media requires no metal backing for improved incinerability and disposal
- \* 1", 2", 4" depths available

**Fresh Air Supreme**

- \* Combination media removes particulate plus gases and odors
- \* 100% synthetic pre-filter charged media
- \* MERV 8
- \* Impregnated carbon removes dust fumes, new furnishing odors, acid gases, VOC's
- \* Self-supported media requires no metal backing for improved incinerability and disposal
- \* 2" and 4" depths available



**IAQ-99**

- \* Combination polyester pre-filter with carbon bonded fibers
- \* 300 grams of carbon per square foot of media (2")
- \* Available in die cut beverage board frame or pad design
- \* 1" and 2" depths available



**IAQ-100 Series**

- \* Select from activated carbon, potassium permanganate or blended media
- \* Honeycomb carbon loading
- \* 25%, 50%, 75% and 100% fill
- \* Steel frame
- \* 1", 2" depths available





### Vari-Pure

- \* High capacity activated carbon filters
- \* Select from activated carbon, impregnated carbon, potassium permanganate or blended media
- \* Effective on a wide variety of gases and odors
- \* Vari-Pure Lite available for lighter odor concentrations
- \* Vari-Sock after-filter prevents carbon dusting downstream
- \* 12" deep



### Vari-Klean

- \* Ultra high efficiency gas phase adsorbers
- \* Highest first pass removal efficiency
- \* Highest carbon loading
- \* Highest activity carbon
- \* Low resistance
- \* Long service life
- \* Clean operation, no dusting
- \* Easy to retrofit with standard filter hardware
- \* Two styles to choose from
- \* Filters individually packaged in a poly bag
- \* Select from four medias



### Replacement Trays and Elements Refillable Carbon Trays

- \* Wide variety of sizes to fit various manufacturers' housings
- \* Cold-rolled steel frame

### AG-12 Element

- \* Fits Purafil and Flanders housings
- \* Refillable design
- \* Contains 30 pounds of carbon

### AG-18 Element

- \* Fits AG-22 element and Purafil PC-22 housings
- \* Refillable and disposable models
- \* Contains 18 pounds of carbon
- \* Convuluted carbon cell
- \* Refillable module
- \* Replaces B-S filter fold
- \* Contains 45 pounds of carbon



### Carbon Filter Housings AG-2000 Front Access Housing

- \* 14 gauge cold rolled steel construction
- \* Easily removable access grid
- \* Contains 90 pounds of carbon (10 trays)

### AG-144 Carbon Housing

- \* 16 gauge cold rolled steel construction
- \* Holds four IAQ-100 carbon panels
- \* Built-in pre-filter and final filter tracks
- \* Contains 48 pounds of carbon

### AG-22 Carbon Housing

- \* 16 gauge cold rolled steel construction
- \* Holds four AG-18 carbon elements
- \* Contains 72 pounds of carbon

### Side Access Carbon Filter Housing

- \* Completely factory assembled
- \* 16 gauge aluminized steel construction
- \* Adaptor flanges to match up with air handling units
- \* Available with 2" pre-filter and/or after-filter track



# PAINT SPRAY BOOTH FILTERS

## OVERVIEW

### OVERSPRAY COLLECTION

The industries that are spraying paint are as diverse as the overspray collection products offered by Research Products (RP). Whether dealing with the Automotive, Furniture, Aerospace, or HVAC industries, there is sure to be a product that will fit your needs. RP is dedicated to helping our customers find solutions to its diverse problems by using our versatile line of dry overspray collectors. Our knowledgeable sales staff is eager to help you find the proper match for your specific overspray collection needs.

### ARRESTING PRINCIPLES

Our product line has been designed to provide customers with optimum performance and extended service life. Our filtering media is fabricated from slit and expanded paper or slit and expanded paper with polyester. The Paint Arrestors are assembled so the intake side has larger openings than the exhaust side. This baffled configuration allows for depth loading for maximum service life.



Additionally, every RP Paint Arrestor, including the prefilter series, has the patented face sheet design. It produces unique airflow patterns that better capture and retain overspray by using less material. You save by:

- Reducing the volume of stored material
- Reducing the number of change-outs
- Reducing down time
- Reducing the amount of material to dispose of

RP Paint Arrestors derive their performance from the filtration principles of straining and impingement. Straining occurs when the paint particle is too big to fit between the openings in the filter media. This occurs with particles that are 20 microns or larger. Impingement occurs when a  
1-800-392-8776

particle is moving along the airstream and its inertia causes the particle to collide with the media fiber. This occurs with particle sizes of about 2 microns. Our product lines that utilize a polyester layer are able to strain out almost all of the remaining paint particles that make it through the paper filter media. Because every application is unique, RP has designed different paper and polyester combinations to accommodate the specific needs of its customers.

### MEASUREMENTS OF PERFORMANCE

When examining the different aspects of an overspray collection system, there are four primary characteristics that are used to rate the effectiveness.

- **Efficiency:** Also known as “arrestance efficiency” will be referred to simply as efficiency throughout this brochure. The efficiency is defined as the average amount of particulate that is collected or removed from the exhaust air. A higher efficiency means that the exhaust air is cleaner, providing cleaner spray booth duct fans, neighboring properties, plant roofs, and cars in the parking lot. Higher efficiencies also mean lower booth maintenance costs and lowers the risk of duct fires with minimal maintenance.
- **Airflow Resistance:** Refers to the static pressure drop (usually measured in inches of water column) across the filter at a given face velocity. As a paint filter loads, the resistance increases. This, in turn, affects service life and holding capacity. Proper airflow is vital to the collection of paint overspray. Airflow takes the path of least resistance, which contributes to uniform loading of overspray collectors.
- **Holding Capacity:** The amount of paint expressed as a weight that a filter can hold at a specified maximum resistance. The depth loading characteristics of the paint collector allows for maximum allowable holding capacity.
- **Service Life:** The length of time, measured in terms of hours or shifts, that a paint filter effectively performs before loading creates a maximum allowable resistance to airflow.



# APPLICATION

## PAINT ARRESTOR MEDIAS

Select from a wide variety of paint overspray collection medias

- Fiberglass
- Stackguard® polyester backed fiberglass
- Type AG/PS polyester
- Expanded paper
- Polyester backed expanded paper

## INTAKE PANEL FILTERS

- Self-sealing - No latches required
- Internal wire support frame
- Tackified for high particle retention
- 90 - 95% arrestance

## DIFFUSION MAX

- Dual layer media construction with scrim backing
- Internal wire support frame

## APPLICATION RECOMMENDATIONS

COATING	COATING CHAR.	SERIES					
		3000	3100	3200	3300	3400	3600
ADHESIVE	A	D	D	E	F	F	F
AIR-DRY ENAMELS	A	D	E	E	F	F	E
BAKE-DRY ENAMELS	A	D	E	E	F	F	E
CLEAR COAT	A	D	E	E	F	E	F
EPOXIES	A	D	E	F	F	F	F
FIBERGLASS	A	D	E	F	F	F	F
GEL COATS	A	D	E	F	F	F	F
HI-SOLIDS ENAMELS	A	D	E	F	F	F	F
LACQUERS	C	D	D	E	F	D	D
PRIMERS - AIR DRY	A	D	E	F	F	F	F
STAINS	B	D	D	E	F	F	E
SEALERS	C	D	D	E	F	D	D
TEFLON	A	D	E	E	F	F	E
URETHANES	A	D	E	F	F	F	F
WATERBORNES	B	D	D	E	F	F	E

**TYPE OF PAINT:**  
 A = Wet and sticky  
 B = Wet and runny  
 C = Dry and dusty

**APPLICATION RECOMMENDATION:**  
 D = Good  
 E = Better  
 F = Best

## PAINT ARRESTOR EFFICIENCY/OVERSPRAY PENETRATION

To assure clean exhaust air, Paint Arrestor selection should be influenced by the volume of paint to be sprayed. Larger volumes require a Paint Arrestor of higher efficiency (see chart on pg 5). The chart shows Paint Arrestor efficiency/overspray penetration based on 1,000 lbs. of overspray solids at the Paint Arrestor.

Example: Booth maintenance would be required ten times more often if the efficiency is 99% versus 99.9%. Both higher efficiency and cleaner exhaust air reduce costs.

*Note: There are minimum efficiency levels required for many situations which we can help determine in a site evaluation at your specific operation. Maximum efficiency is very important when a volatile organic compound (VOC) abatement system such as a thermal oxidizer is used. For best performance, the abatement system must remain clean.*

PAINT ARRESTOR EFFICIENCY	OVERSPRAY PENETRATION	OVERSPRAY RELEASED TO THE EXHAUST AIR
90%	10%	100 lbs.
92%	8%	80 lbs.
94%	6%	60 lbs.
96%	4%	40 lbs.
98%	2%	20 lbs.
99%	1%	10 lbs.
99.5%	0.5%	5 lbs.
99.9%	0.1%	1 lbs

## PAINT ARRESTOR PRODUCTS

PRODUCT	VELOCITY (fpm)	RESISTANCE (in. w.g.)	AVERAGE EFFICIENCY RANGE
<b>3000 SERIES</b> <b>Standard RP Paint Arrestors</b>	100	0.020	97.5 to 99.22% high solids bake enamel
	200	0.060	93.0 to 94.0% waterborne bake enamel
	300	0.120	Tested using two pads in tandem
<b>3100 SERIES</b> <b>Standard High Capacity RP Paint Arrestors</b>	100	0.020	94.0 to 96.0% high solids bake enamel
	200	0.050	91.5 to 92.5% waterborne bake enamel
	300	0.100	Tested using two pads in tandem
<b>3200 SERIES Spr-Gard</b> <b>High Efficiency RP Paint Arrestors</b>	100	0.055	98.5 to 99.5% high solids bake enamel
	200	0.125	97.0 to 98.0% waterborne bake enamel
	300	0.225	94.0 to 95.0% lacquer  Tested using two pads in tandem
<b>3300 SERIES Spr-Gard</b> <b>High Efficiency RP Paint Arrestors</b>	100	0.055	99.5 to 99.9% high solids bake enamel
	200	0.136	98.5 to 99.2% waterborne bake enamel
	300	0.256	95.0 to 96.0% lacquer  Tested using single pad
<b>3400 SERIES Spr-Gard</b> <b>High Capacity High Efficiency RP Paint Arrestors</b>	100	0.065	99.5 to 99.9% high solids bake enamel
	200	0.153	
	300	0.283	Tested using single pad
<b>3600 SERIES Spr-Gard</b> <b>High Capacity High Efficiency RP Paint Arrestors</b>	100	0.03	99.0 to 99.4% on high solids bake enamel
	200	0.08	
	300	0.19	Tested using single pad

### 3500 SERIES

The 3500 series was designed as a life extending prefilter. The main application of this product is for use in conjunction with any primary stage overspray filter. Utilizing the 3500 series Paint Arrestor will save on the costs associated with replacing the more expensive primary filter by prolonging its service life. Additionally, it can be used in any spray coating application, plus it increases the flexibility of your operation.

*Performance information shown was obtained using equipment similar to that incorporated by the American Society of Heating, Refrigerating and Air Conditioning Engineers (ASHRAE) in evaluating performance of air cleaning media. Details regarding equipment testing procedure and test results are available by writing for Reprint No. 4259.*

40 CFR PART 63 NESHAP

*This filter series (3000, 3200, 3300, 3400, 3600) meets GACT for sources subject to SUBPART HHHHHH (Paint Stripping and Miscellaneous Surface Coatings at Area Sources) and SUBPART XXXXXX (Area Source Standards for Nine Metal Fabrication and Finishing Source Categories)*

*(>=98% Efficient when tested by ASHRAE Method 52.1 in accordance with NESHAP)*



# 3000 SERIES

## STANDARD RP PAINT ARRESTORS



**OVERVIEW:** The 3000 Series provides good all around performance for general applications and can be used for most coatings applied by the various spray coating methods. The 3000 series provides an environmentally friendly, degradable solution for any customer's economic overspray needs. Available in both rolls and modular pad form, its recommended usage consists of two pads or rolls assembled in tandem.

### PAINT ARRESTOR IDENTIFICATION

**PA Model:** 3000 Series RP Standard Paint Arrestor  
**RP Test #:** 2056  
**Number of pads in series:** 2  
**Pad type** (Production / Experimental): Production

### PAINT IDENTIFICATION

**Paint type:** High Solids  
**Density (lb./gal.):** 12.8  
**Thinner used:** Xylol  
**Viscosity (Ford #4 - sec):** 50 seconds (~1.6 Poise)

### TEST CONDITIONS

**Duct velocity (fpm):** 150  
**Gun manufacturer & model:** DeVilbiss JGA-502  
**Tank pressure (psi):** 10  
**Gun distance from PA (ft.):** 6  
**Paint feedrate (gal./hr.):** 1  
**Nozzle & air cap:** 54FX  
**Atomization pressure (psi):** 20

### TEST SUMMARY

Pressure drop (" w.c.)	Efficiency (%)	Paint Collection (lb)
Initial: 0.04	Initial: 99.0	Total: 6.3
Final: 0.10	Average: 98.9	Run off: 0

Face velocity (fpm)	50	100	150	200
Initial Pressure Drop ("w.c.)	<0.01	0.02	0.04	0.06

### 3000 SERIES RESISTANCE VS. CAPACITY

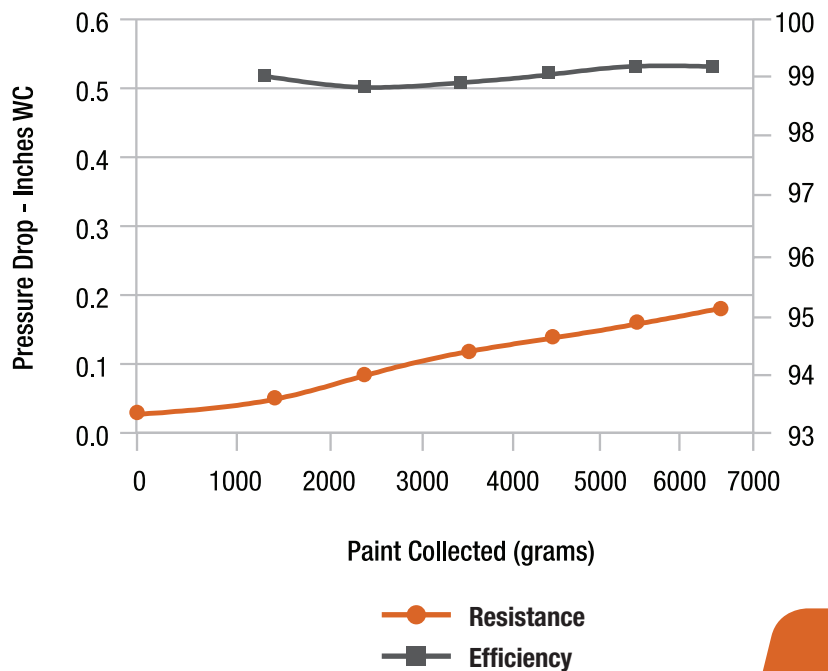



# 3100 SERIES

STANDARD HIGH EFFICIENCY RP PAINT ARRESTORS

**OVERVIEW:** This product has all the characteristics of the 3000 Series, but is designed to hold up to twice the overspray before changing is required. This double service life makes this series ideal for high production applications and wherever a large volume of coating is applied in a relatively small booth space. This longer service life results in less down time, fewer changeovers and greater economy. Rolls or pads are used in tandem. The product is ideal for heavy, tacky coatings or slower drying finishes, but it is not recommended for quick dry lacquer type coatings.

## PAINT ARRESTOR IDENTIFICATION

**PA Model:** 3100 Series Standard High Efficiency RP Paint Arrestor  
**RP Test #:** 2072  
**Number of pads in series:** 2  
**Pad type (Production / Experimental):** Production

## PAINT IDENTIFICATION

**Paint type:** High Solids  
**Density (lb./gal.):** 12.9  
**Thinner used:** Xylol  
**Viscosity (Ford #4 - sec):** 54 seconds (~1.8 Poise)

## TEST CONDITIONS

**Duct velocity (fpm):** 150  
**Gun manufacturer & model:** DeVilbiss JGA-502  
**Tank pressure (psi):** 10  
**Gun distance from PA (ft.):** 6  
**Paint feedrate (gal./hr.):** 1  
**Nozzle & air cap:** 54FX  
**Atomization pressure (psi):** 20

## TEST SUMMARY

Pressure drop (" w.c.)	Efficiency (%)	Paint Collection (lb)
Initial: 0.03	Initial: 98.39	Total: 22.7
Final: 0.10	Average: 98.83	Run off: 13.5

Face velocity (fpm)	50	100	150	200
Initial Pressure Drop ("w.c.)	<0.01	0.02	0.03	0.06

## 3100 SERIES RESISTANCE VS. CAPACITY

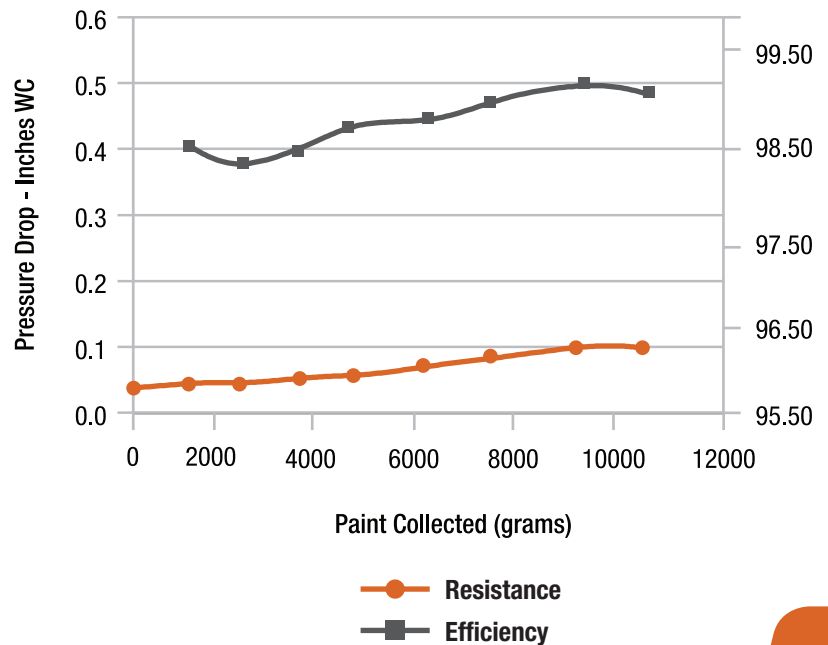





# 3200 SERIES

## SPRA-GARD HIGH EFFICIENCY RP PAINT ARRESTORS

**OVERVIEW:** This overspray product is also similar to the 3000 Series, but has an added polyester backing which increases the overall efficiency needed for very finely atomized overspray particles. Producing excellent efficiencies, the 3200 Series results in a 50% reduction of overspray up the stack, and the poly backing makes it ideal for coating at any rate of production. It is available in pad or roll form and its recommended use is two in tandem.

### PAINT ARRESTOR IDENTIFICATION

**PA Model:** 3200 Series Spr-Gard High Efficiency RP Paint Arrestor  
**RP Test #:** 2054  
**Number of pads in series:** 2  
**Pad type (Production / Experimental):** Production

### PAINT IDENTIFICATION

**Paint type:** High Solids  
**Density (lb./gal.):** 12.9  
**Thinner used:** Xylol  
**Viscosity (Ford #4 - sec):** 49 seconds (~1.58 Poise)

### TEST CONDITIONS

**Duct velocity (fpm):** 150  
**Gun manufacturer & model:** DeVilbiss JGA-502  
**Tank pressure (psi):** 10  
**Gun distance from PA (ft.):** 6  
**Paint feedrate (gal./hr.):** 1  
**Nozzle & air cap:** 54FX  
**Atomization pressure (psi):** 20

### TEST SUMMARY

Pressure drop (" w.c.)	Efficiency (%)	Paint Collection (lb)
Initial: 0.04	Initial: 99.20	Total: 6.40
Final: 0.20	Average: 99.41	Run off: 0.0

Face velocity (fpm)	50	100	150	200
Initial Pressure Drop ("w.c.)	<0.06	0.02	0.04	0.06

### 3200 SERIES RESISTANCE VS. CAPACITY

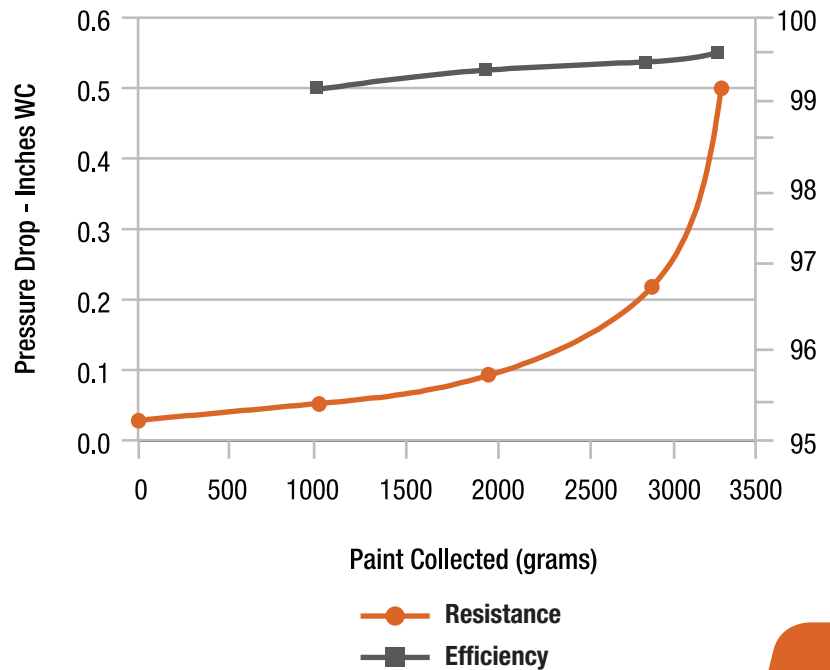

# 3300 SERIES

SPRA-GARD HIGH EFFICIENCY RP PAINT ARRESTORS



**OVERVIEW:** The finest efficiencies possible can be achieved with this series of Paint Arrestors. This performance is achieved through the use of a high-density polyester backing which is structurally very strong. Due to the high efficiency, only one role or pad layer is necessary.

## PAINT ARRESTOR IDENTIFICATION

**PA Model:** 3300 Series Spra-Gard High Efficiency RP Paint Arrestor  
**RP Test #:** 2097  
**Number of pads in series:** 1  
**Pad type (Production / Experimental):** Production

## PAINT IDENTIFICATION

**Paint type:** High Solids  
**Density (lb./gal.):** 12.9  
**Thinner used:** Xylol  
**Viscosity (Ford #4 - sec):** 51 seconds (~1.62 Poise)

## TEST CONDITIONS

**Duct velocity (fpm):** 150  
**Gun manufacturer & model:** DeVilbiss JGA-502  
**Tank pressure (psi):** 10  
**Gun distance from PA (ft.):** 6  
**Paint feedrate (gal./hr.):** 1  
**Nozzle & air cap:** 54FX  
**Atomization pressure (psi):** 20

## TEST SUMMARY

Pressure drop (" w.c.)	Efficiency (%)	Paint Collection (lb)
Initial: 0.07	Initial: 99.70	Total: 4.20
Final: 0.20	Average: 99.66	Run off: 0.0

Face velocity (fpm)	50	100	150	200
Initial Pressure Drop ("w.c.)	<0.02	0.04	0.07	0.11

## 3300 SERIES RESISTANCE VS. CAPACITY

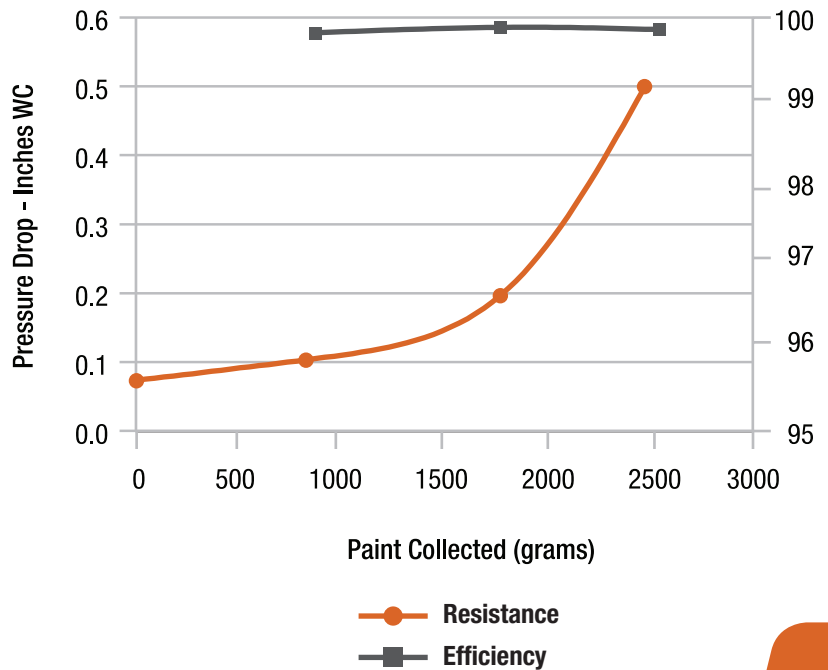



# 3400SERIES

SPRA-GARD HIGH CAPACITY HIGH EFFICIENCY RP PAINT ARRESTORS



**OVERVIEW:** This series has all the features and advantages of the 3300 Series, plus a longer service life. It is ideal for extremely high production applications because both peak efficiency and service life can be achieved, thereby reducing downtime and increasing the time interval between changes.

## PAINT ARRESTOR IDENTIFICATION

**PA Model:** 3400 Series Spr-Gard High Capacity High Efficiency RP Paint Arrestor  
**RP Test #:** 2051  
**Number of pads in series:** 1  
**Pad type (Production / Experimental):** Production

## PAINT IDENTIFICATION

**Paint type:** High Solids  
**Density (lb./gal.):** 12.9  
**Thinner used:** Xylol  
**Viscosity (Ford #4 - sec):** 52 seconds

## TEST CONDITIONS

**Duct velocity (fpm):** 150  
**Gun manufacturer & model:** DeVilbiss JGA-502  
**Tank pressure (psi):** 10  
**Gun distance from PA (ft.):** 6  
**Paint feedrate (gal./hr.):** 1  
**Nozzle & air cap:** 54FX  
**Atomization pressure (psi):** 20

## TEST SUMMARY

Pressure drop (" w.c.)	Efficiency (%)	Paint Collection (lb)
Initial: 0.07	Initial: 99.79	Total: 5.10
Final: 0.10	Average: 99.79	Run off: 0.0

Face velocity (fpm)	50	100	150	200
Initial Pressure Drop ("w.c.)	<0.02	0.04	0.07	0.11

## 3400 SERIES RESISTANCE VS. CAPACITY

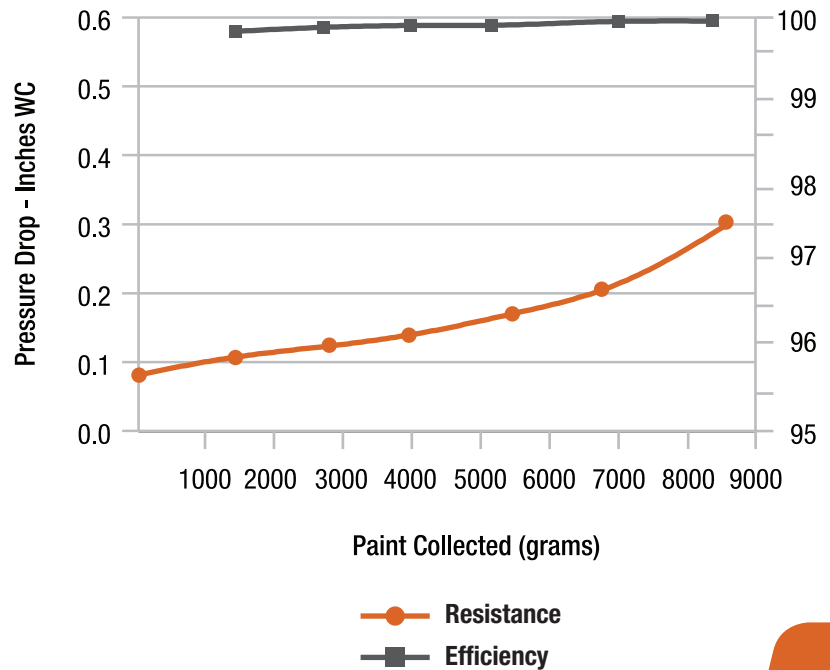

# 3600 SERIES

SPRA-GARD HIGH EFFICIENCY RP PAINT ARRESTORS



**OVERVIEW:** The 3600 Series offers both longevity and efficiency. This series has all of the advantages of the 3200 Series plus a longer service life. This product works well in high volume spray applications because the high capacity paper provides service life and the polyester provides high efficiency for small particles. Cleaner paint exhaust stacks and fewer changes of products make the 3600 a preferred total cost solution for many overspray applications.

## PAINT ARRESTOR IDENTIFICATION

**PA Model:** 3600 Series Spragard High Efficiency RP Paint Arrestors  
**RP Test #:** 3094  
**Number of pads in series:** 1  
**Pad type (Production / Experimental):** Production

## PAINT IDENTIFICATION

**Paint type:** High Solids  
**Density (lb./gal.):** 13.73  
**Thinner used:** Xylol  
**Viscosity (Ford #4 - sec):** 53 seconds

## TEST CONDITIONS

**Duct velocity (fpm):** 150  
**Gun manufacturer & model:** DeVilbiss JGA-502  
**Tank pressure (psi):** 10  
**Gun distance from PA (ft.):** 6  
**Paint feedrate (gal./hr.):** 1  
**Nozzle & air cap:** 54FX  
**Atomization pressure (psi):** 20

## TEST SUMMARY

Pressure drop (" w.c.)	Efficiency (%)	Paint Collection (lb)
Initial: 0.06	Initial: 98.68	Total: 18.73
Final: 0.50	Average: 99.37	Run off: 7.53

Face velocity (fpm)	50	100	150	200
Initial Pressure Drop ("w.c.)	<0.01	0.03	0.06	0.08

## 3600 SERIES RESISTANCE VS. CAPACITY

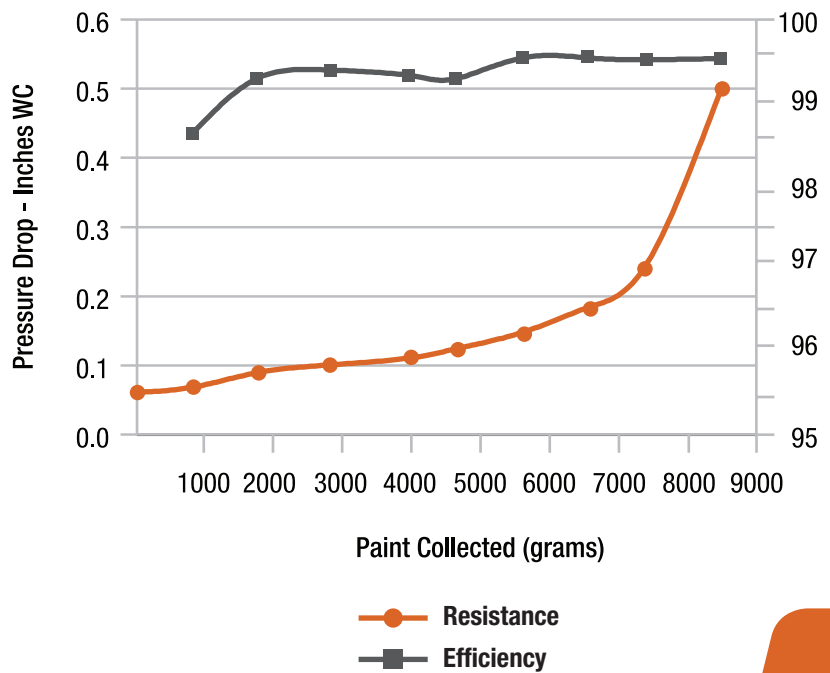



# ACCESSORIES

## SPRA-PAK™

### PAINT ARRESTOR ASSEMBLY

**OVERVIEW:** The Spra-Pak assembly is designed to provide a simple, inexpensive package for converting any existing spray booth to efficient, long-lasting RP Paint Arrestor roll media. The 20" wide frame provides universal application for any size or type booth. This will result in substantial savings in booth maintenance costs and increased spray booth operating efficiency.

This conversion could result in thousands of dollars saved by eliminating the expensive replacement of an outdated or rusted-out water wash booth. Water wash booth conversion is easily done by removing plumbing and sheet metal obstructions and then positioning the proper number of Spra-Pak assemblies in place of the wash down sheet. (Reservoir may not have to be removed unless it is an obstruction to proper assembly or booth operation.)

Additional conversion grids are available to upgrade from any dry filter booth including pleated media, polyester, fiberglass, or cardboard overspray collectors to RP Paint Arrestor rolls. Installation instructions are provided with the product.

**1:** Determine number of 20" wide x 72" high Spra-Paks required for the booth. Example (7' high x 10' wide booth requires six Spra-Paks with a 4" blank off on one side and 12" blank off at top).

The exploded view (Figure 1) shows (1) Stock No. 1030 Spra-Pak Paint Arrestor assembly. Remove the (2) Stock No. 1015, 20" wide x 36" high media support grids, (1) Stock No. 1016, upper media support grid and the nuts and bolts taped to the center channel. Set aside for installation in step 5.

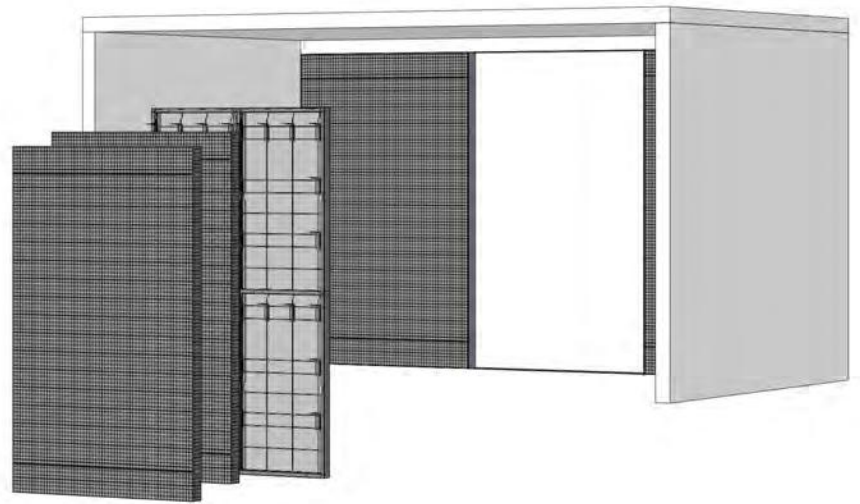

**Figure 1**

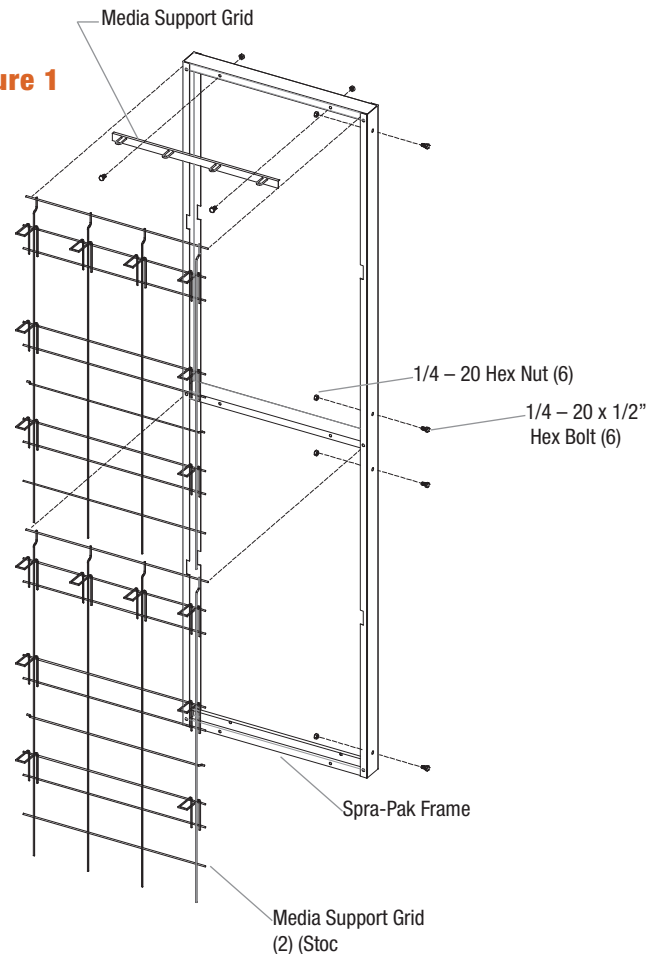

**Figure 2**

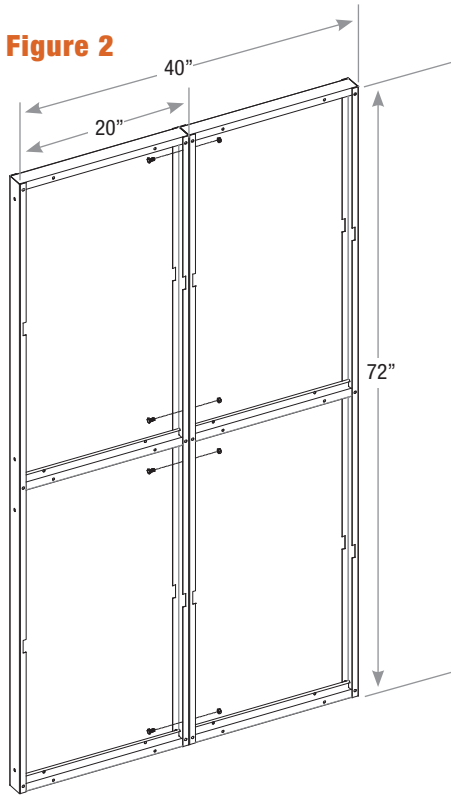

**Figure 4**

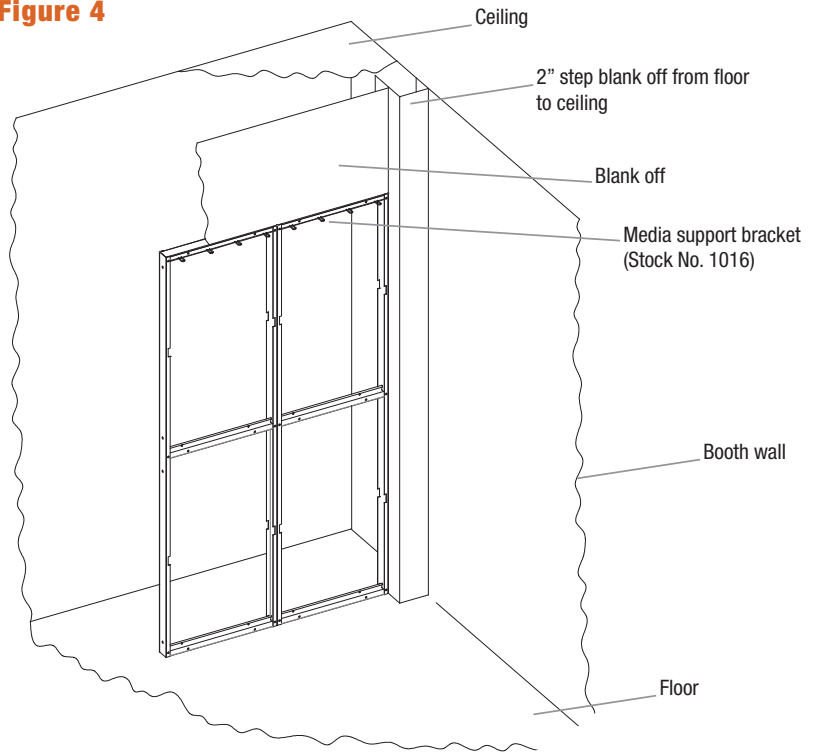

**2:** Bolt the required number of frame channels together either on the floor or in the booth, as shown in Figure 2. (Two assemblies are joined using four 1/4" - 20 x 1/2 Hex head bolts and nuts - furnished.)

**4:** After the Spra-Pak is mounted securely in the booth with appropriate metal blank off in place, attach the upper media support grid as shown in Figure 4 and Figure 1. Additional horizontal and vertical support may be required.

**Figure 3**

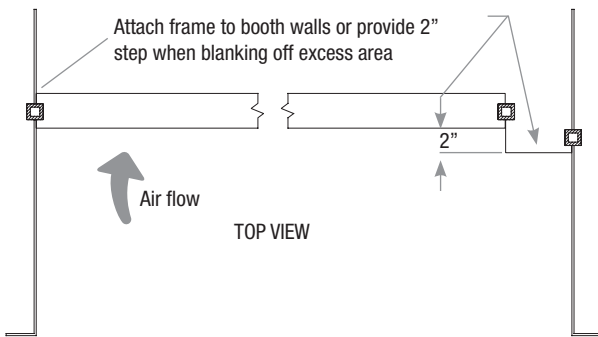

**Figure 5**

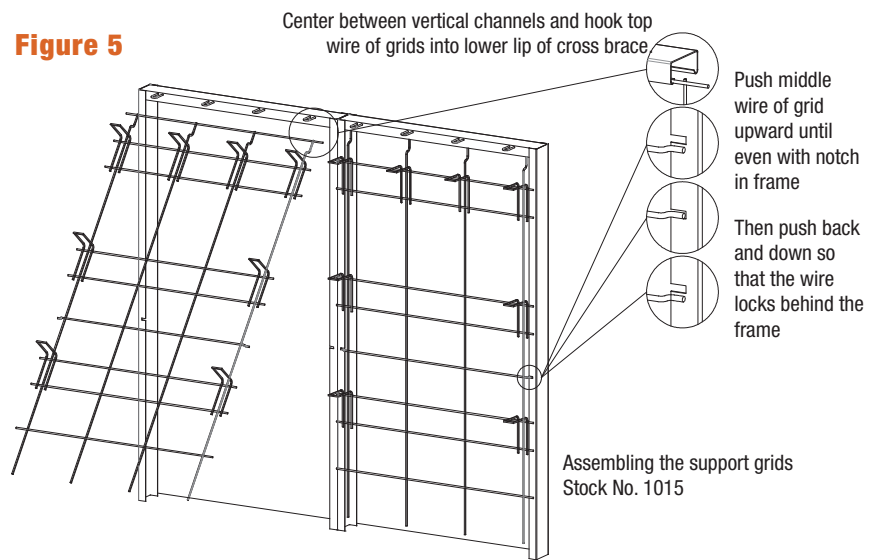

**3:** See suggested procedure (Figure 3) for special 2" offset sheet metal blank off and method of attaching to booth framework. This eliminates any bypass air and promotes easy cleaning.

**5:** Install support grids as shown in Figure 5 and Figure 1. Hang 6' length of roll media vertically by pushing securely onto support grid. Overlap vertical seam to eliminate any bypass air.



# ACCESSORIES

## CONVERSION GRIDS

STOCK NO. 1017 & 1018

**OVERVIEW:** Do you have an existing spray booth that utilizes 20" x 20" or 20" x 25" modules? Research Products offers a convenient and economical method for converting a modular booth so that it can utilize RP Paint Arrestor roll media. These conversion grids will take the time, manpower, and cost from the conversion process and will prevent the end-user from needing to design or assemble a new booth. When the conversion grids are properly specified with RP Paint Arrestors, you can expect cleaner ducts, exhaust fans, and stacks. This leads to reduced maintenance activities, fire hazards, and coating items you do not want (roof, parked cars, neighboring properties). When looking at a per pound basis of overspray, RP Paint Arrestors offer the best means of overspray collection available today. Installation instructions are provided with the product.

### INSTALLATION INSTRUCTIONS:

- 1: Determine the number of Conversion Grids Stock No. 1017 or 1018 by counting the number of modular holding frames. One grid is needed per holding frame as shown in Figure 1.
- 2: Determine the number of media support grids Stock No. 1016 by counting the number of modular holding frames across the top row of the booth. The No. 1016 above the top row helps to prevent bypass air.
- 3: Remove all pads, snap-in grids, or pad holding devices from the holding frame.
- 4: Install Conversion Grid as shown in Figures 2, 3, and 4.
- 5: Hang length of RP Paint Arrestor Roll Media vertically by stretching slightly and pushing securely onto No. 1016 support grid and conversion grid. Overlap vertical seams to eliminate any bypass air.

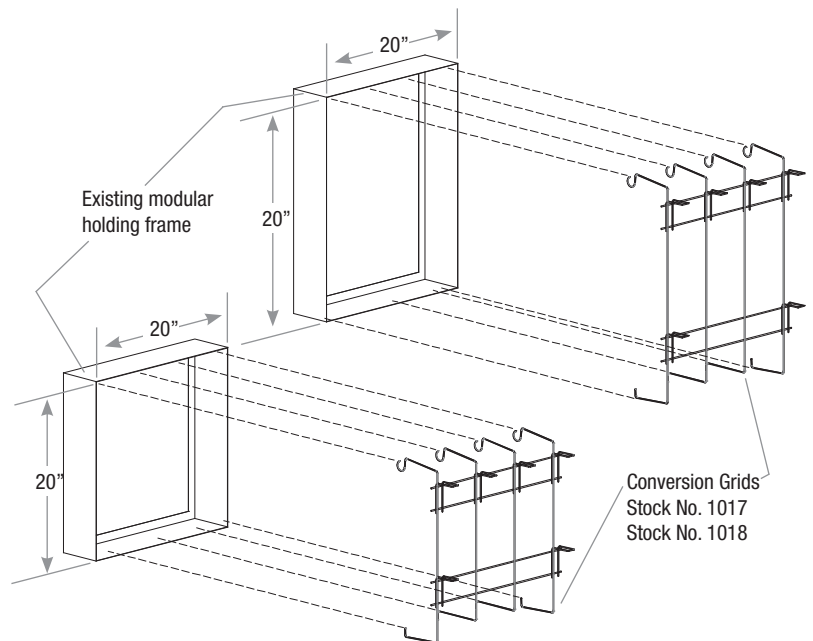
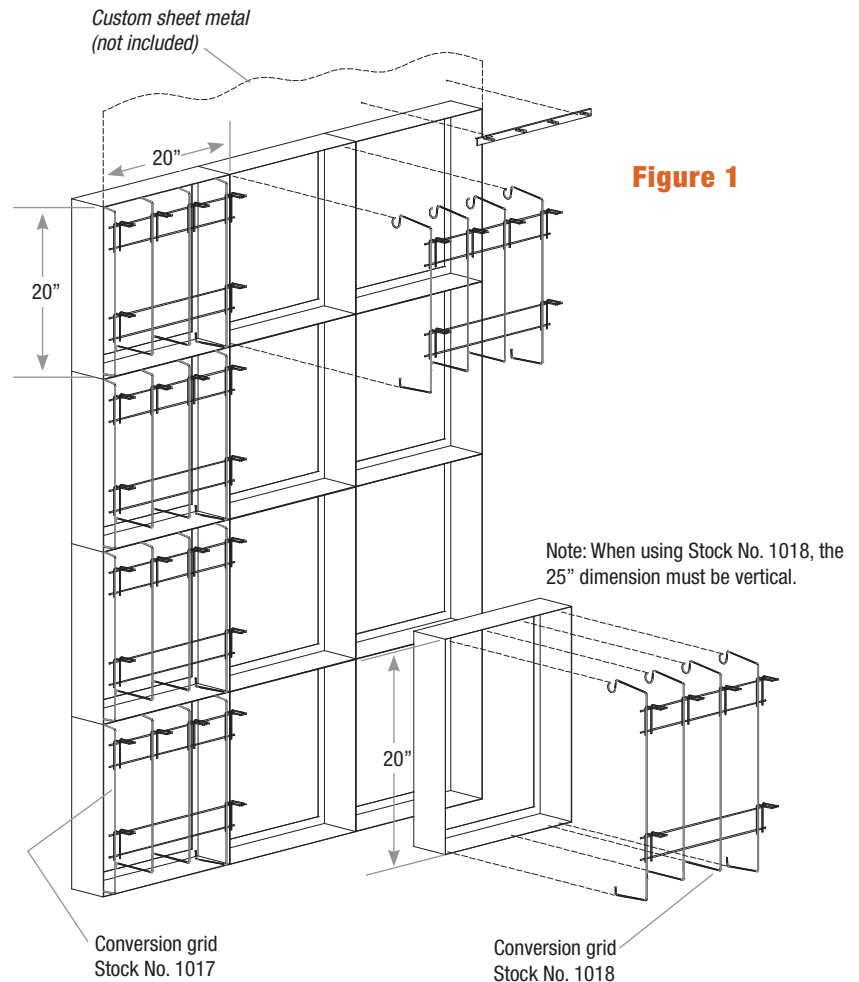

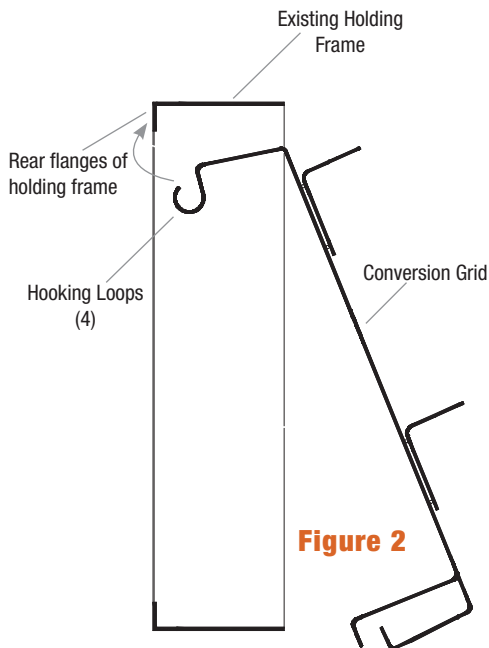

Place top of Conversion Grid into top rear flange of holding frame with the rear flange of the holding frame inserted into the (4) hooking loops on the grid.

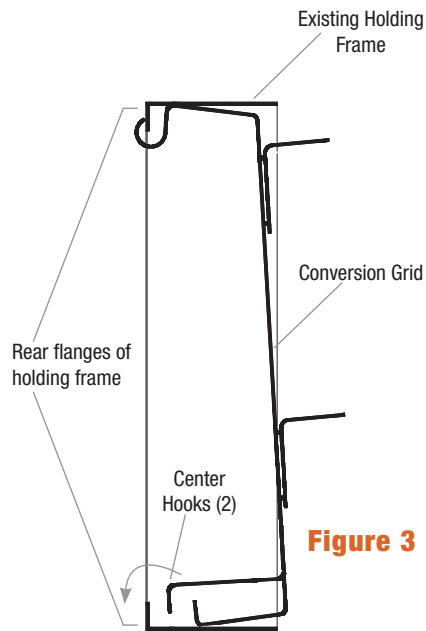

Push bottom of Conversion Grid into holding frame. Lift the (2) bottom center hooks over the rear flange of the holding frame locking the Conversion Grid into place.

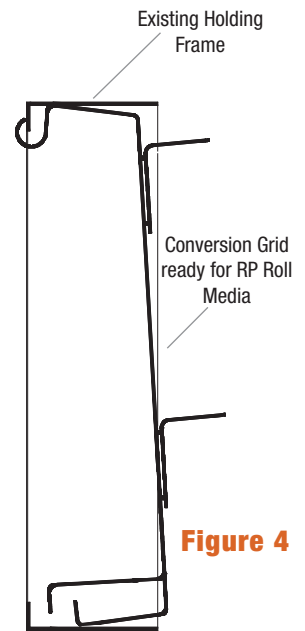

Conversion Grid is now ready for installation of RP Roll Media.

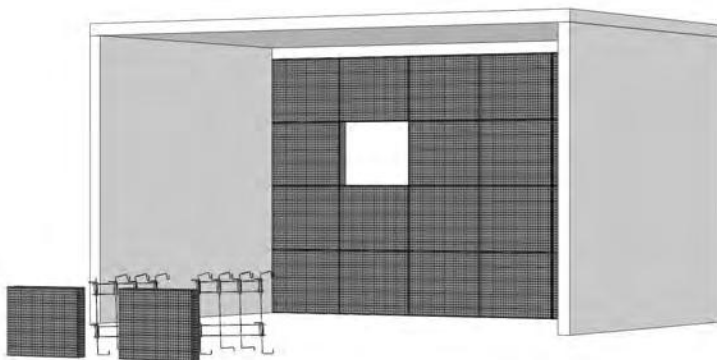

**MODULAR BOOTH DESIGN FOR PADS:** An RP Paint Arrestor bank is easily assembled by riveting together the number of holding frames required for a specific installation. Any bypass space is blanked off with sheet metal. A downstream Snap-In Grid is placed in each holding frame. An RP Paint Arrestor pad is then placed against the installed grid. Another grid is positioned and a second pad is installed to complete the installation.

## OSHA 1910.107 STANDARD FOR DESIGN

This standard requires that spraying be so designed, installed, and maintained that the average air velocity over the open face of the booth shall not be less than the lower explosive limit of the solvents being sprayed which is usually above 100 lineal feet per minute. Electrostatic spraying operations may be conducted with an air velocity over the open face of the booth of not less than 60 lineal feet per minute or more, depending on certain variables (see OSHA 1910.107 Standard for the full scope of spray booth operating requirements). The reasoning behind this standard relates primarily to health concerns; however, it also provides for proper collection of airborne solids. A higher initial start-up velocity should be used in order to maintain airflow above the minimum required. This is caused by the gradual increase in resistance as the overspray collectors become loaded. Research Products' Paint Arrestors will perform well at high velocities; however, when considering energy usage, this is not recommended.



# PARTICULATE EMISSIONS: SPRAY BOOTHS

Many codes list an allowable particulate emission from the paint booth stack in terms of grains per cubic foot of exhaust air. The form below assists in calculating the total allowable weight of the emissions and provides an estimate of what is actually going out of the Paint Arrestor-equipped paint booth stack.

## TO ACCOMPLISH THESE CALCULATIONS, THE FOLLOWING INFORMATION IS REQUIRED:

- a) Width and height of booth – feet \_\_\_\_\_
- b) Velocity of air in booth – fpm \_\_\_\_\_
- c) Allowable emission – grains per cubic feet \_\_\_\_\_
- d) Paint sprayed per hour – gallons \_\_\_\_\_
- e) Weight of paint – percent \_\_\_\_\_
- f) Solids in paint – percent \_\_\_\_\_
- g) Overspray – percent \_\_\_\_\_
- h) Overspray passing through the collection system  
(100% minus efficiency) – percent \_\_\_\_\_

**EXAMPLE:** The following example can be used as a guideline to help you in your specific application.

The sample calculation is based on a 7' by 10' booth, which is a very popular size produced by several manufacturers. To calculate the allowable emission in pounds per hour, we assumed a face velocity through the booth of 125 FPM. The 70 square feet times 125 FPM results in an exhaust volume of 8,750 CFM times 60 minutes is 525,000 cubic feet of air per hour. In the example, we used an allowable emission rate of 0.003 grains per cubic foot. This is the most rigid particulate emission control requirement. The allowable emission rate, 0.003 times 525,000 is 1,575 grains per hour, divided by 7,000 grains per pound results in an allowable emission of 0.225 pounds of particulate per hour.

To calculate the stack emissions estimate, information, when known, was used and if not available, assumptions were made. In the example, three gallons of paint per hour weighing nine pounds per gallon were sprayed. The solids are 50% and the overspray was also calculated at 50%.

The calculations for the example using the above assumptions resulted in an estimate of 6.75 pounds of overspray approaching the Paint Arrestor collection system. In the example, the High Efficiency Spra-Gard has a minimum efficiency of 97%. Therefore, three percent maximum would pass through. The calculated emission would be 0.203 pounds per hour. This value (0.203) is less than the allowable emission (0.225), resulting in acceptable emissions.

Frequently, the booth exhaust exceeds 125 FPM. This results in an increase in allowable emission, since it varies directly with the exhaust air volume. Lower solid content and/or increased transfer result in less emission, assuring compliance with a margin to spare.

## CALCULATION SHEET – PAINT BOOTH PARTICULATE EMISSIONS EXAMPLE

### INFORMATION NEEDED:

- A. Width and height of booth (feet).....7' x 10'
- B. Velocity of air in booth (fpm)..... 125 fpm
- C. Allowable emission (grains per cubic feet)..... 0.003
- D. Paint sprayed per hour (gallons) ..... 3
- E. Weight of paint (percent) ..... 9
- F. Solids in paint (percent)..... 50
- G. Overspray (percent)..... 50
- H. Overspray passing through the collections system  
(100% minus efficiency – gallons)..... 3

### ALLOWABLE EMISSION:

- W 10 x H 7 (a)..... 70 sq. ft (area)
- Multiply by (b)..... 125 fpm (velocity)
- To get..... 8,750 cfm (volume)
- Multiply by..... 60 minutes
- To get..... 525,000 cubic feet/hour (volume)
- Multiply (c)..... 0.003 grains/cubit ft. (allowable emission)
- To get..... 1,575 grains/hour(allowable emission)
- Divide by ..... 7,000 grains/pound
- To get..... 0.225 pounds/hour (allowable emission)

### CALCULATED EMISSION:

- Paint used (d)..... 3 gallons/hour
- Multiply by (e)..... 9 pounds/gallon (weight per gallon)
- To get..... 27 pounds/hour (paint sprayed)
- Multiply by (f)..... 50% solids
- To get..... 13.5 pounds solids/hour
- Multiply by (g)..... 50% overspray
- To get..... 6.75 pounds overspray/hour
- Multiply by (h)..... 0.03 paint passing through
- To get..... 0.203 pounds/hour (calculated emission)



# ULTRAVIOLET LIGHT AIR PURIFICATION SYSTEM

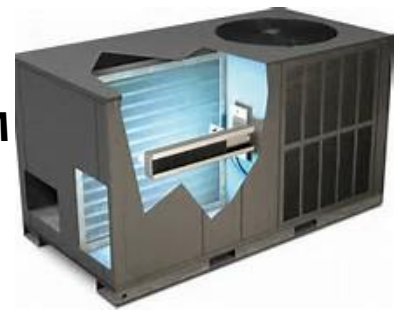

- Full Line:**
- Residential
  - Commercial
  - Custom Applications

## APCO TUV-APCO-ER2

The original full-size APACO features a 13" Fresh-Aire UV lamp and 6 activated carbon cells. Models include low-voltage 18-32 VAC single or dual (ER, DER) and line-voltage 120-277 single or dual (SI, DI). APACO Dual systems come with a second remote UV lamp which can be mounted where needed for additional UV disinfection.

- Odor control
- Cleans coil
- Indoor air quality
- Kills over 99% of airborne mold, bacteria, viruses and allergens after the first 24 hours of use.
- Advanced photocatalytic oxidation
- Germ killing power of UVC light

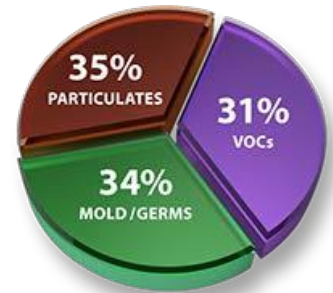

# RESIDENTIAL AIR FILTRATION PRODUCTS



## Sani-Pan Strips

- Kills mold
- EPA registered
- Lasts up to 6 months
- Easy to install
- Dependable protection

## Pan Pills

Prevents drain pan overflow. A quaternary-based biocide, formulated in tablet form and enclosed in a plastic fiber housing. Permitted by EPA to make a claim of 99% kill of Legionella, Pneumophia and Salmonella Typhi. Provides 3 months protection and is available in four treatment sizes.

- STRIP = up to 3 tons
- FTC = less than 5 tons
- ATC = greater than 5 tons
- 45TON = up to 45 tons

State-of-the-art in water activated, time-released polymer technology. When wet, the solid packaged strip will release the active ingredients, leaving only the used polymer shell to discard. When the drain pan is dry, the treatment remains dormant. Sani-Pan Strips will continue activating and deactivating as wet and dry conditions change. Sani-Pan Strips will be effective for 3-6 months, depending on cooling requirements. Kills mold, mildew and fungus causing bacteria.

SPS-1T = 1 ton or <  
SPS-10T = 5-10 ton

SPS-3T = 1-3 ton  
SPS-20T = 10-20 ton

SPS-5T = 3-5 ton  
SPS-50T = 20-50 ton



## Continental Contitech V-Belts



V-Belts are the driving force behind some of the most vital systems in any automobile, powering generators, fans, water pumps, AC compressors, and power steering systems.

All ContiTech V-Belts are quiet, OE-quality and virtually service free. The only time these belts require attention is during installation.

Designed to be oil-resistant and temperature-stable from -22F to 176F (30C to 80C), ContiTech V-Belts are open-flanked, toothed, and shaped for greater traction and torque.

High performance construction features include a synthetic fiber fabric cover, a special polyester cord designed to permit tightly controlled shrink, plus a polychloroprene rubber body, integrally molded cogs, and raw edges.

With a wide variety of widths and lengths to choose from, FHP, Hy-T Plus, Hy-T Wedge, Torque-Flex and Hy-T Torque Team

### **Also available**

- Light duty sheaves and accessories
- Split steel sheaves
- Air movement sheaves
- Integral H.P. sheaves/ bushings
- Timing pulleys
- Couplings
- Variable speed drives

## Fenner Power Twist



PowerTwist Plus is the everyday industrial workhorse for power transmission applications. Perfectly suited to Z/10, 3L, A/13, B/17, and C/22 drives and can be installed on existing pulleys with no changes in set-up. Fenner Drives PowerTwist Plus V Belts minimize downtime with no tools required, easy installation in minutes without tear-downs or struggling with rusted motor bases. Have an application where static electricity is a concern? PowerTwist Plus Antistatic is the answer... with all the benefits of standard PowerTwist Plus and the best antistatic properties of any V belt on the market.

Instead of trying to carry all the endless V belt sizes you might need, with PowerTwist Plus, you only need to stock the most common cross sections - A/13 and B/17 - and you'll have almost 100%, on-site availability guaranteed. With PowerTwist Plus you will reduce the inventory dollars you have tied up in replacement belts and still have instant availability so you have the right belt, at the right time!



## Everpure/ Pentair



Quality water is important for taste, brewing, carbonation, steaming, equipment protection and more. Water used to make coffee, espresso beverages, fountain beverages, drinking water and ice must be potable under local requirements and USEPA drinking water standards.

- Coffee/Tea filtration systems
- Fountain beverage filtration systems
- Water boost systems
- Drinking water filtration
- Endurance filtration system
- Combination filtration systems
- Ultrafiltration system
- Reverse osmosis systems
- Softeners
- Filter heads
- Replacement cartridges
- General beverage systems

- Espresso softening & filtration systems
- Fountain filtration systems/ chloramines systems
- Ice filtration systems
- Steam treatment filtration systems
- Scale reduction
- Hybrid filtration systems
- Water management
- Ro replacement cartridges/accessories
- Softeners/warewashing
- Manifold systems
- Value filtration
- Surge tanks/accessories/ replacement parts



## WATER TREATMENT SOLUTIONS EVERYWHERE YOU NEED THEM.



## HARMSCO VESSELS, CARTRIDGES AND SPARE PARTS



### **SB and HB Hurricane Housings**

Industrial/ Municipal (SB) Commercial (HP), combination cyclone separator and cartridge filter in a single design patented up-flow design flow rates to 2,400 GPM (SB), 150 GPM (HP).

### **WB and WB 5x170FL WaterBetter Housings**

Commercial, single cartridge design patented up-flow design coated option available flow rates to 150 GPM (WB) and to 600 GPM (WB 5x170FL). Offered in 304/316 stainless steel.

### **HMC Filter Housings**

Industrial/ Municipal, built to ASME design standards, U-stamp option available standard hold down plates to accept DOE, 222/flat and 222/fin style cartridges. Flow rates to 1,400 GPM, offered in 304/316 stainless steel.



### **HIF Filter Housings**

Commercial, patented up-flow design coated option available flow rates to 800 GPM, offered in 304/316 stainless steel.

### **BC and HBC Band Clamp Housings**

Commercial, FNPT, BSTP, flange and victaulic connections available (BC series only) Patented up-flow design (BC series only) Flow rate to 600 GPM, offered in 304/316 stainless steel.

### **FSSS Single Cartridge Housings**

Commercial/ Industrial, designed for 300 PSI DOE or 222/flat configurations available, offered in 304/316 stainless steel.

### **HMB, HSB and BCB Bag Housings**

Industrial/ Municipal, u-stamp option available (HMB, HSB) standard #1, #2 and extended bag options. Flow rates to 2,400 GPM, offered in 304/316 stainless steel.



**NSF filter housing and filters available.**

### **Hurricane Cartridges**

High flow, high surface area, low initial pressure drop provides longer filter life. High temperature cartridges available, lowest cost per filtered gallon based on surface area.

### **Premium & WaterBetter Cartridges**

2-1/2" and 2-3/4" O.D. pleated cartridges designed for Harmsco HIF, band clamp and competitive filter housings. Available in 9-3/4", 10", 20", 30" and 40" cartridge lengths. All cartridges shrink wrapped.

### **701 Series Cartridges**

2-1/2" O.D. pleated cartridges designed for Harmsco and competitive filter housings 9-3/4", 10", 20", 30" and 40" lengths; polyester, Harmsco free and Poly-pleat media. All cartridges shrink wrapped.

### **Calypso Blue Cartridges**

4-1/2" O.D. pleated cartridges designed for Harmsco HIF, band clamp and single cartridge housings. Premium series offers up to 12 sq. ft. of media per 9-3/4" length. WaterBetter series 9.5 sq. ft. All cartridges shrink wrapped.

### **SureSafe Cartridges**

Antimicrobial cartridge media prohibits growth of bacteria and mold on filter cartridges. Offered in 20 and 50 micron ratings and a wide range of cartridge sizes. Agion Silver Zeolite is FDA tested and registered with the EPA.

### **Poly-Pleat Cartridges**

Pleated one micron absolute cartridges for safe, cyst free drinking water. Available in a wide range of cartridge sizes.

### **Carbon Cartridges**

Hurricane, HAC and WaterBetter carbon cartridges for high chlorine, taste, odor, lead, THM and organic chemical removal. Available in a wide range of cartridge sizes, including Hurricane 170 series.

### **All Poly/High Purity Cartridges**

Available in, polypropylene - PP; polyethersulfone - PES membrane; Microfiberglass - FG; Nylon 6.6 - NY and Plus + Nylon 6.6 - NYP; Teflon - TF membrane and polysulfone (PS). Available in DOE, 222w/fin, 222 w/flat cap, 226 w/flat cap, 226 w/fin, 213 internal o-ring. Available in Hurricane sizes 40, 90, 170 and 0.2, 0.45, 1, 5, 10, 20, 50micron ratings

### **High Temperature Cartridges**

Pleated polyester or cellulose phenolic media. Two temperature ratings to choose from: 200F and 250F. Designed for Hurricane and WaterBetter housings.

### **Liquid Filter Bags**

"V" seal ring bags available to prevent by-pass polypropylene and polyester options available. Broad chemical compatibility industry #1, #2 and EXT extended bag size available.





# INTERNALLY SUPPORTED FILTERS



## Series AG Filter Elements

For use in Farr® HP Series systems

- Deep pleated media design
- Collapsible for compact shipping and storage
- Three depths - 8", 12", 24"
- Four efficiencies -
  - MERV 14 (90 - 95%)
  - MERV 13 (80 - 85%)
  - MERV 11 (60 - 65%)
  - MERV 7 (25 - 30%)



# CARTRIDGES



- Replacement cartridges for all types of gas turbine barrier systems and dust collector systems.
- All filters are constructed to strict specifications and are available in multiple sizes and media configurations to meet a variety of application and environmental requirements.

- High Performance Media Options: ICF-11HF, ICF-12, ICF-13 & ICF-15.
- High moisture-resistance.
- Multiple media options for different environments (High Flow Spun Bond, Synthetic, Paper, Nano, Melt Blown, Poly Propylene, Synthetic Paper).

- Durable construction.
- Replaces OEM manufactured filters.
- Multiple core and end cap options.
- Uniform pleat spacing.

**ASHRAE Test Standards**  
52.1-1999 and 52.2-2007.

**MERV Performance Rating:** 11-15 Consult Bulletins: PB-798-20 and K-GT909

# HOLDING FRAMES & LATCHES



*Uni-Lok® Filter Holding Frame*

## Uni-Lok® Filter Holding Frames

- 16 gauge galvanized steel
- Pre-punched mounting holes
- Factory applied gaskets
- Wide variety of latches to hold all types and sizes of filters

## Type AG-8 Filter Holding Frames

- Replacement for Farr® Type 8 frames and latches

## Type HDS HEPA Holding Frame

- Creates high integrity seal for HEPA installations
- 16 gauge aluminized steel construction
- Two depths - holds 5-7/8" or 11-1/2" deep filters
- Spring loaded clamping bolt

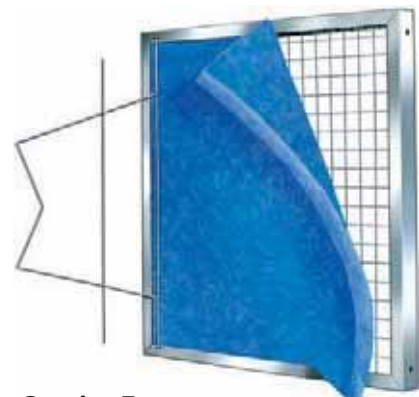

## Service Frame

- Holds filter media pads
- Sized to fit inside Uni-Lok, Type AG-8 or other manufacturers' brands of filter holding frames
- 22 gauge galvanized steel frame
- 1/2", 1", 2" thicknesses
- Wire support grid - both sides

## SIDE ACCESS HOUSINGS



*Flat Bank Housing*

### Flat Bank Housings

- Single stage units
- Holds 2" or 4" thick filters
- 16 gauge aluminized steel construction

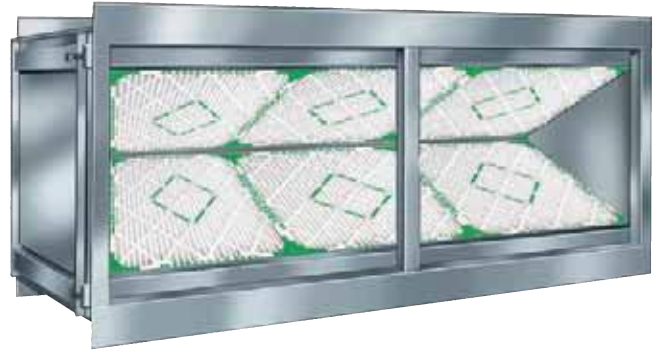

*V-Bank Housing*

### V-Bank Housings

- V-bank filter arrangement
- Holds 2" thick filters
- 16 gauge aluminized steel construction
- Adaptor flanges for air handling units or ductwork arrangements

### HEPA Lock Side Access Housing

- 16 gauge aluminized steel construction
- 24" deep - holds 5-7/8" or 11-1/2" deep filters
- Lever action filter clamping mechanism



*HEPA Lock Side  
Access Housing*



*Two Stage Housing*

### Two Stage Housings

- Five depths - 12", 21", 26", 38", 42"
- 2" or 4" prefilter track with 1" track for header style final filter
- 16 gauge aluminized steel construction
- Adaptor flanges for air handling units or ductwork arrangements



**ASHRAE SIDE ACCESS CARBON FILTER HOUSING (CH)**

DATE \_\_\_\_\_  
 APPROVED  APPROVED AS NOTED   
 SIGNATURE \_\_\_\_\_

MODEL NUMBER 02CH02 - 02-00 - 34 - AS

**SIZE CODES**

Width "W"		1	02	03	04	05	06	07	08	09	10
Height "H"		11-1/2	23-1/2	35	47	58-1/2	70-1/2	82	94	105-1/2	117-1/2
01	15										
02	27										
03	39										
04	51										
05	63										
06	75										

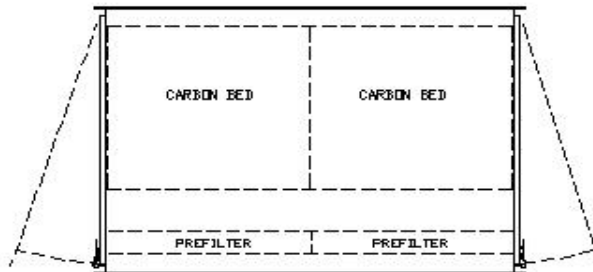

TOP VIEW

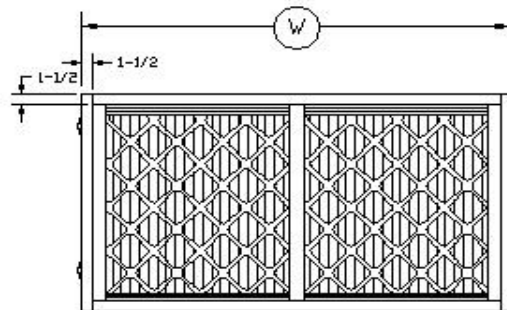

UPSTREAM VIEW

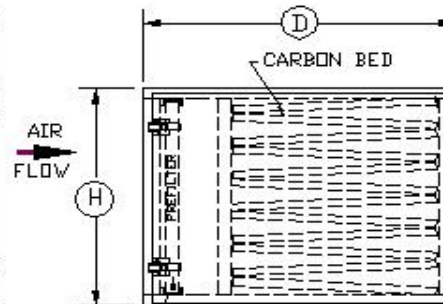

DOOR VIEW

**LEAD TIME OPTION STANDARD 4 WEEK**

HOUSING DEPTH (SELECT ONE)

- 34" 2" Pre-filter / 1" Carbon Tray
- 34" 4" Pre-filter / 1" Carbon Tray
- 34" 1" Carbon Tray / 2" Final Filter
- 34" 1" Carbon Tray / 4" Final Filter
- 39" 2" Pre-filter / 1" Carbon Tray / 2" Final Filter
- 39" 4" Pre-filter / 1" Carbon Tray / 4" Final Filter

DIMENSIONS HxW (SELECT ONE)

02CH02  
 23-1/2 W = Width (Inches)  
 27 H = Height (Inches)  
 34 D = Depth (Inches)

MATERIALS (SELECT ONE)

- AS = 16 GA Aluminized Steel
- SS = 16 GA 304 Stainless Steel

FACTORY OPTIONS

- WC = Weathercap
- DW = Double Wall Insulation (Includes Weathercap)
- DF = Double Flange
- VF = Vertical Flow
- SP = Static Pressure Ports  
1 Port (Specify Location)
- HP = High Pressure
- SL = Support Legs
- T = Transition
- O = Other (Specify)

<Special Notes>

**SPECIFICATIONS**

1. 16 GA Material Construction.
2. Aluminum Filter Tracks.
3. Door perimeters are sealed with EPDM gasket.
4. Doors Fitted with over-center draw latches.
5. Doors on Both Sides.

# FULL SIZE TRAYS 12  
 # HALF SIZE TRAYS 0  
 # FULL SIZE FILTERS 1  
 # HALF SIZE FILTERS 0  
 RATED AIR FLOW (CFM) 2000 @ 500 FPM  
 WEIGHT OF UNIT





**ASHRAE SIDE ACCESS FLAT BANK FILTER HOUSING (FB)**

DATE \_\_\_\_\_

APPROVED  APPROVED AS NOTED

SIGNATURE \_\_\_\_\_

MODEL NUMBER \_\_\_\_\_

**SIZE CODES**

Width "W"	01	02	03	04	05	06	07	08	09	10
Height "H"	11-1/2	23-1/2	35	47	58-1/2	70-1/2	82	94	105-1/2	117-1/2
01	14-11/16									
02	26-11/16									
03	38-3/8									
04	50-3/8									
05	62-1/16									
06	74-1/16									
07	85-3/4									

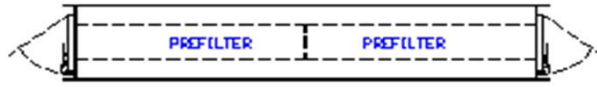

TOP VIEW

Galvanized prefilter tracks are available for 2" or 4" filters.

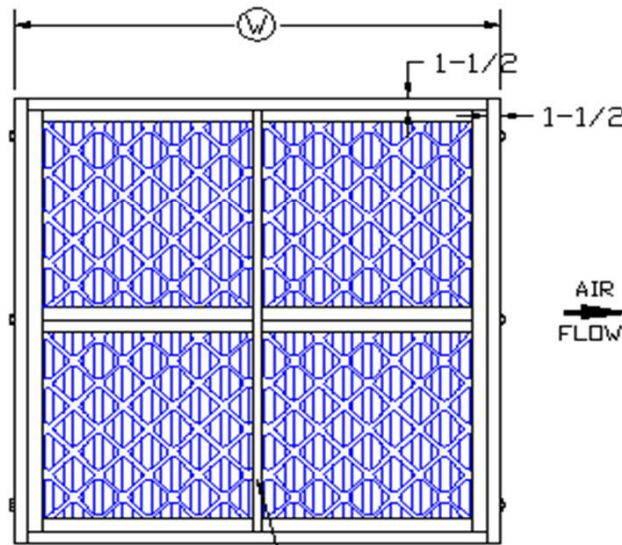
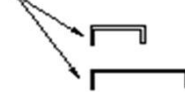

UPSTREAM VIEW

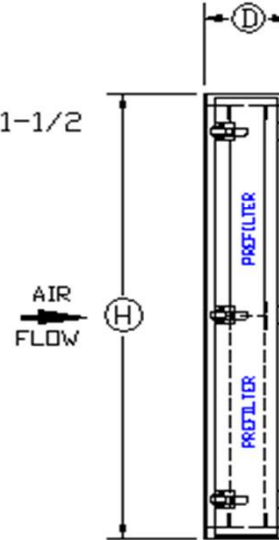

DOOR VIEW

- Standard 4 Week
- 3 Week Expedite
- 2 Week Expedite

**HOUSING DEPTH (SELECT ONE)**

- 05 - 5-3/16" Depth  
2" Filter Track
- 07 - 7-3/16" Depth  
4" Filter Track

**DIMENSIONS HxW (USE CHART FOR DIMENSIONS)**

\_\_\_\_\_ W = Width (Inches)  
\_\_\_\_\_ H = Height (Inches)

**MATERIALS (SELECT ONE)**

- AS = 16 GA Aluminized Steel
- SS = 16 GA 304 Stainless Steel

**FACTORY OPTIONS**

- WC = Weathercap
- DW = Double Wall Insulation
- BK = Hanger Brackets, (4) Sides on Top
- DF = Double Flange
- VF = Vertical Flow
- SP = Static Pressure Ports  
Specify Location: \_\_\_\_\_
- HP = High Pressure up to 10"
- SL = Support Legs
- T = Transition
- O = Other (Specify)

<Special Notes>

**SPECIFICATIONS**

1. 16 GA Material Construction.
2. Aluminum Filter Tracks with Woven Nylon Pile Seal.
3. Doors Sealed with Closed Cell Neoprene Gasket.
4. Polyurethane Foam Inside Access Doors Gaskets Filters.
5. Metal to Metal Components Sealed with Silicone Compound.
6. Doors Fitted with Quick Action, Positive Pressure Trip Lock Latches.
7. Doors on Both Sides.
8. Units Over 10 Wide or 7 High are Produced by Combining Smaller Units Together.
9. Maximum Static Pressure 4.0" W.G. Positive or Negative

# FULL SIZE FILTERS \_\_\_\_\_  
# HALF SIZE FILTERS \_\_\_\_\_  
RATED AIR FLOW (CFM) \_\_\_\_\_ @ 500 FPM



# HEPA TWO STAGE LOCK HOUSING (HFL)

DATE \_\_\_\_\_

APPROVED  APPROVED AS NOTED

SIGNATURE \_\_\_\_\_

MODEL NUMBER \_\_\_\_\_

		SIZE CODES							
Width "W"		01	02	03	04	05	06	07	08
Height "H"		14-7/8	26-7/8	38-7/8	50-7/8	62-7/8	74-7/8	86-7/8	98-7/8
01	15-3/16								
02	27-3/16								
03	39-1/2								
04	51-1/2								
05	63-7/8								
06	75-7/8								

(3) 1/4" FNPT  
STATIC TAPS

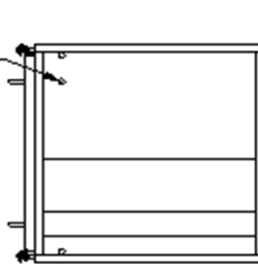

TOP VIEW

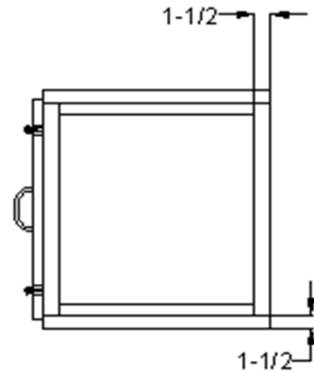
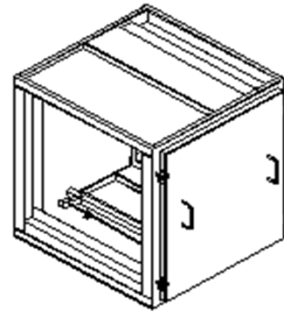

FLANGE DETAIL

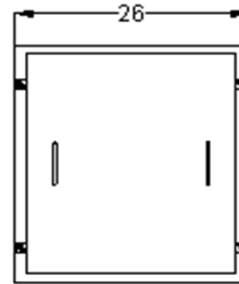

GASKET SEAL SIDE VIEW

- 6 Week Standard
- 5 Week Expedite
- 4 Week Expedite
- 3 Week Expedite
- 2 Week Expedite

PREFILTER DEPTH (SELECT ONE)

- 02 = 2" Prefilter Track
- 04 = 4" Prefilter Track

HEPA DEPTH (SELECT ONE)

- 06 = 5-7/8" Depth HEPA Filter
- 12 = 11-1/2" Depth HEPA Filter

DIMENSIONS HxW (USE CHART FOR DIMENSIONS)

\_\_\_\_\_ W = Width (Inches)  
 \_\_\_\_\_ H = Height (Inches)

MATERIALS (SELECT ONE)

- AS = 16 GA Aluminized Steel
- SS = 16 GA 304 Stainless Steel

FACTORY OPTIONS

- WC = Weathercap
- DW = Double Wall Insulation
- BK = Hanger Brackets, (4) Sides on Top
- DF = Double Flange
- VF = Vertical Flow
- SP = Static Pressure Ports  
Specify Location: \_\_\_\_\_
- HP = High Pressure up to 10"
- SL = Support Legs
- T = Transition
- O = Other (Specify)

<Special Notes>

# FULL SIZE FILTERS \_\_\_\_\_  
 # HALF SIZE FILTERS \_\_\_\_\_  
 RATED AIR FLOW (CFM) \_\_\_\_\_ @ 500 FPM

SPECIFICATIONS

1. 16 GA Material Construction.
2. Aluminum Pre-Filter Tracks with Woven Nylon Pile Seal.
3. Positive Over-Center HEPA Lock Mechanism, 600 Ft-Lb Pressure per Filter.
4. Doors Sealed with EPDM Gasket.
5. Metal to Metal Components Sealed with Silicone Compound.
6. Doors Fully Removable, Secured with Hand-Turn Knobs.
7. Doors on Both Sides.
8. Units Over 10 Wide or 7 High are Produced by Combining Smaller Units Together.
9. Maximum Static Pressure 5.0" W.G. Positive or Negative



**ASHRAE TWO-STAGE SIDE ACCESS FILTER HOUSING (SA)**

DATE \_\_\_\_\_  
 APPROVED  APPROVED AS NOTED   
 SIGNATURE \_\_\_\_\_

MODEL NUMBER \_\_\_\_\_

		SIZE CODES									
Width "W"	Height "H"	01	02	03	04	05	06	07	08	09	10
01	14-11/16	11-1/2	23-1/2	35	47	58-1/2	70-1/2	82	94	105-1/2	117-1/2

01	14-11/16
02	26-11/16
03	38-3/8
04	50-3/8
05	62-1/16
06	74-1/16
07	85-3/4

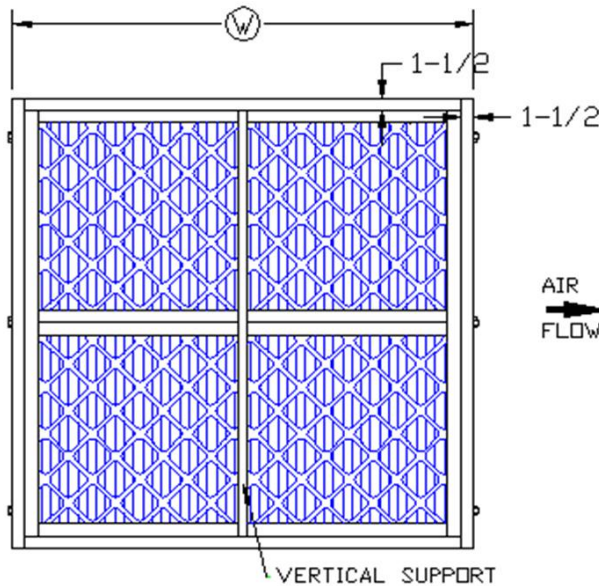
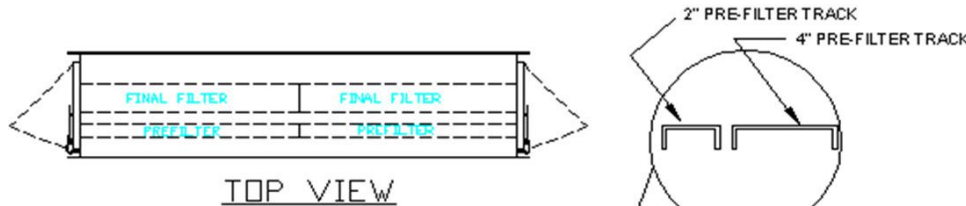

UPSTREAM VIEW

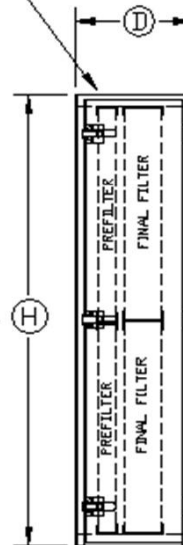

DOOR VIEW

- 4 Weed Standard
- 3 Week Expedite
- 2 Week Expedite

HOUSING DEPTH (SELECT ONE)

- 12 - 12" Depth (D)  
2" Pre-Filter Track w/ 4" Final Filter Track
- 14 - 14" Depth (D)  
4" Pre-Filter Track w/ 4" Final Filter Track

DIMENSIONS HxW (USE CHART FOR DIMENSIONS)

\_\_\_\_\_ W = Width (Inches)  
 \_\_\_\_\_ H = Height (Inches)

MATERIALS (SELECT ONE)

- AS = 16 GA Aluminized Steel
- SS = 16 GA 304 Stainless Steel

FACTORY OPTIONS

- WC = Weathercap
- DW = Double Wall Insulation
- BK = Hanger Brackets, (4) Sides on Top
- DF = Double Flange
- VF = Vertical Flow
- SP = Static Pressure Ports  
Specify Location: \_\_\_\_\_
- HP = High Pressure up to 10"
- SL = Support Legs
- T = Transition
- O = Other (Specify)

<Special Notes>

**SPECIFICATIONS**

1. 16 GA Material Construction.
2. Aluminum Filter Tracks with Woven Nylon Pile Seal.
3. Doors Sealed with Closed Cell Neoprene Gasket.
4. Polyurethane Foam Inside Access Doors Gaskets Filters.
5. Metal to Metal Components Sealed with Silicone Compound.
6. Doors Fitted with Quick Action, Positive Pressure Trip Lock Latches.
7. Doors on Both Sides.
8. Units Over 10 Wide or 7 high are Produced by Combining Smaller Units Together.
9. Maximum Static Pressure 4.0" W.G. Positive or Negative

# FULL SIZE FILTERS \_\_\_\_\_  
 # HALF SIZE FILTERS \_\_\_\_\_  
 RATED AIR FLOW (CFM) \_\_\_\_\_ @ 500 FPM





MODEL NUMBER \_\_\_\_\_

**ASHRAE SIDE ACCESS V-BANK FILTER HOUSING (VB)**

DATE \_\_\_\_\_

APPROVED  APPROVED AS NOTED

SIGNATURE \_\_\_\_\_

		SIZE CODES									
Width "W"		01	02	03	04	05	06	07	08	09	10
Height "H"		11-1/2	23-1/2	35	47	58-1/2	70-1/2	82	94	105-1/2	117-1/2

01	14-11/16
02	26-11/16
03	38-3/8
04	50-3/8
05	62-1/16
06	74-1/16
07	85-3/4

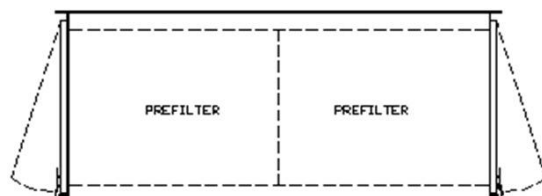

Channel for 2" filters and formed foga. tracks for 4" filters is available.

TOP VIEW

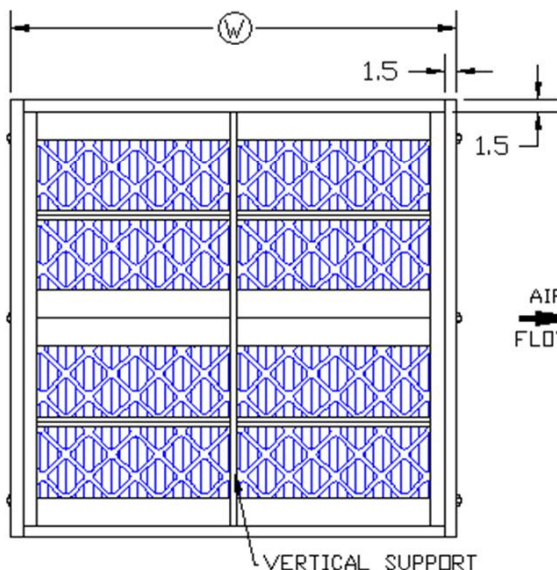

UPSTREAM SIDE

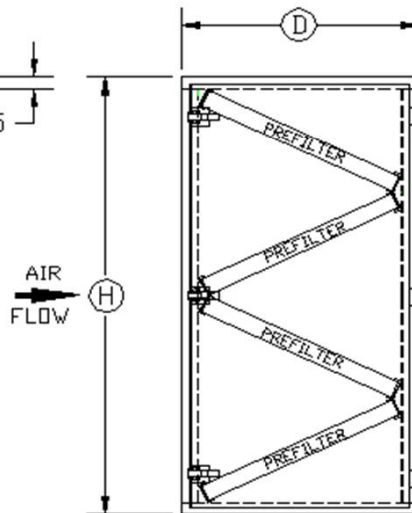

DOOR VIEW

- 4 Week Standard
- 3 Week Expedite
- 2 Week Expedite

HOUSING DEPTH (SELECT ONE)

- 28 - 27-5/8" depth  
2" Filter Track
- 29 - 28-5/8" depth  
4" Filter Track

DIMENSIONS HxW (USE CHART FOR DIMENSIONS)

\_\_\_\_\_ W = Width (Inches)  
\_\_\_\_\_ H = Height (Inches)

MATERIALS (SELECT ONE)

- AS = 16 GA Aluminized Steel
- SS = 16 GA 304 Stainless Steel

FACTORY OPTIONS

- WC = Weathercap
- DW = Double Wall Insulation
- BK = Hanger Brackets, (4) Sides on Top
- DF = Double Flange
- VF = Vertical Flow
- SP = Static Pressure Ports  
Specify Location: \_\_\_\_\_
- HP = High Pressure up to 10"
- SL = Support Legs
- T = Transition
- O = Other (Specify)

<Special Notes>

SPECIFICATIONS

- 16 GA Material Construction.
- Aluminum Filter Tracks with Woven Nylon Pile Seal.
- Doors Sealed with Closed Cell Neoprene Gasket.
- Polyurethane Foam Inside Access Doors Gaskets Filters.
- Metal to Metal Components Sealed with Silicone Compound.
- Doors Fitted with Quick Action, Positive Pressure Trip Lock Latches.
- Doors on Both Sides.
- Units Over 10 Wide or 7 High are Produced by Combining Smaller Units Together.
- Maximum Static Pressure 4.0" W.G. Positive or Negative

# FULL SIZE FILTERS \_\_\_\_\_  
# HALF SIZE FILTERS \_\_\_\_\_  
RATED AIR FLOW (CFM) \_\_\_\_\_ @ 500 FPM

# Capture Pollutants, Energy Savings, and LEED Credits with **PREVENT**® Equipment Protection



## Save Energy

In order to operate efficiently, outdoor HVAC equipment must be clean and free of debris. Natural pollutants, such as dust, tree seeds, leaves, and other debris can very easily clog air intake louvers and condenser fins.

According to EPA research, **as little as 0.042"** of dirt on an air conditioning coil can **reduce its efficiency by 21%**.

An article in the Refrigeration Service Engineers Society Journal states that a 5-ton A/C system could use as much as **37% more power if the coils are dirty**.

Permatron's PreVent® filters not only capture the pollutants that decrease HVAC equipment efficiency, but are cleanable, re-useable and fit any equipment.



This unprotected condenser fin is completely impacted by cottonwood seedlings, rendering it drastically inefficient or completely inoperable. Only labor-intensive cleaning using messy chemicals can restore this piece of equipment to working order.

## \$\$ Save Money

A 5-ton A/C unit protected with PreVent® equipment filters will cost up to **\$450 less per season** to operate than an unprotected A/C unit with dirty condenser fins, assuming an electricity cost of \$0.12 per kWh, 1,500 hours worth of A/C unit run time in a 90-day cooling season.



## Economy of Scale

Typically, larger A/C and air intake equipment experience a higher percentage of efficiency increase when operating with clean coils. As the size of your HVAC system or the length of your cooling season increases, so does your potential energy and utility bill savings.



## Testimonials

"The installation of the Permatron PreVent filter has saved us money, reduced downtime, and to date eliminated any possible environmental outages."

- Gary Wilcox, Production Supervisor, Osram-Sylvania

"By using the PreVent filters, we've reduced our seasonal filtration costs by almost 70% and our maintenance and cleaning man-hours are about a third of what they were with the old filtration equipment."

-Angelo Carrieri, Maintenance Superintendent, Water and Sanitation District, Parker, Colorado

## How PreVent® Filters Work

PreVent® filters are made from either polypropylene or PVC-coated polyester high abrasion media, and are all UV protected and capable of withstanding extreme indoor and outdoor environments.

The inherent electrostatic charge of the woven black polypropylene filter media enhances the filter's ability to capture and hold smaller particles.

Independent laboratory testing\* showed that PreVent® Equipment Protection Filters cause less than 1% change in compressor discharge pressure, resulting in negligible performance degradation due to pressure drop.

\* ARI Standard 210-240-2006 Performance Rating of Unitary Air Conditioning and Air Source Heat Pump Equipment Underwriters Laboratories, Plano, TX



PreVent® filters made this large-scale economizer setup in California more energy efficient.



# LEED Credits and Other Benefits



## LEED Certification

Permatron's PreVent® filters can help your building achieve certification through the U.S. Green Building Council's LEED Rating System by contributing to the following credits:

### Energy and Atmosphere (EA)

#### Credit 1: Optimize Energy Performance

**Intent:** To achieve increasing levels of energy performance beyond the prerequisite standard to reduce environmental and economic impacts associated with excessive energy use.

#### How PreVent filters are consistent with this Intent:

PreVent® filters provide facility managers with an easily maintained, re-useable, highly efficient means of ensuring optimum HVAC equipment efficiency by preventing condenser fins, coils, and air intake grills from becoming clogged and inefficient, thereby **eliminating potential excessive HVAC equipment energy use.**

### Indoor Environmental Quality (IEQ)

#### Credit 5: Indoor Chemical and Pollutant Source Control

**Intent:** To minimize building occupant exposure to potentially hazardous particulates and chemical pollutants.

#### How PreVent filters are consistent with this Intent:

PreVent® filters serve as a first line of defense against any pollutants in outside air being brought into a building. These filters **reduce the amount of pollutants** that reach indoor HVAC equipment filters, freeing up these filters to capture other particulates and extending their useful life.

### Innovation & Design (ID)

#### Credit 1: Innovation in Design

**Intent:** To provide design teams and projects the opportunity to achieve exceptional performance above the requirements set by the LEED Green Building Rating System and/or innovative performance in Green Building categories not specifically addressed by the LEED Green Building Rating System.

#### How PreVent filters are consistent with this Intent:

The benefits of PreVent® filters transcend the current definitions of LEED credits by providing **improved energy efficiency and reduced indoor pollutant levels** by means of a technology that is not specifically listed in the requirement of each credit. Benefits related to each credit listed above can be quantified using laboratory testing data and historical energy savings records.



A York chiller with ineffective, disposable filters.



The same York chiller with durable, cleanable PreVent equipment protection filters.



## Reduce Your Carbon Footprint

A 5-ton A/C unit protected with PreVent® equipment filters, using approximately 3,750 less kWh of electricity per season, will generate approximately **5,625 lbs less CO<sub>2</sub> emissions** than an unprotected A/C unit with dirty condenser fins, assuming 1.5 lbs CO<sub>2</sub> emissions per kWh of electricity (U.S. EPA, Feb. 2011: <http://www.epa.gov/greenpower/pubs/calcmeth.htm>).



Custom-shaped triangle filters ensure optimum efficiency and simplify maintenance on this Carrier micro-channel coil laboratory cooling equipment in Plano, Texas.

## PREVENT® Filters Can Be Used On:

- Air Conditioner Condensers
- Rooftop Heating/Cooling Units
- Air-to-Air Heat Pumps
- Fresh Air Louvers
- Chillers / Cooling Towers
- Economizer Equipment
- Any other outdoor equipment with an air intake
- Indoor equipment (coolers, freezers, etc)



PreVent filters installed on these 40-ton Carrier rooftop units eliminated the need for frequent, extensive chemical cleaning in a Colorado town subject to intense cottonwood seedling invasions.



# Air Intake Filter Solution Quote Form

Brauer Supply Company  
1218 South Vandeventer Ave., St. Louis, MO 63110  
[www.brauersupply.com](http://www.brauersupply.com)

Fax: 314-534-2019, Phone: 314-534-7150, email: [filters@brauersupply.com](mailto:filters@brauersupply.com)

Company Name: _____	Contact Name: _____
Contact Phone Number: _____	Cell: _____ Fax: _____
Company Address: _____	City: _____ State: _____ Zip: _____
Email Address: _____	

Please indicate both the *inside dimension* and *outside dimension of the lower frame*.

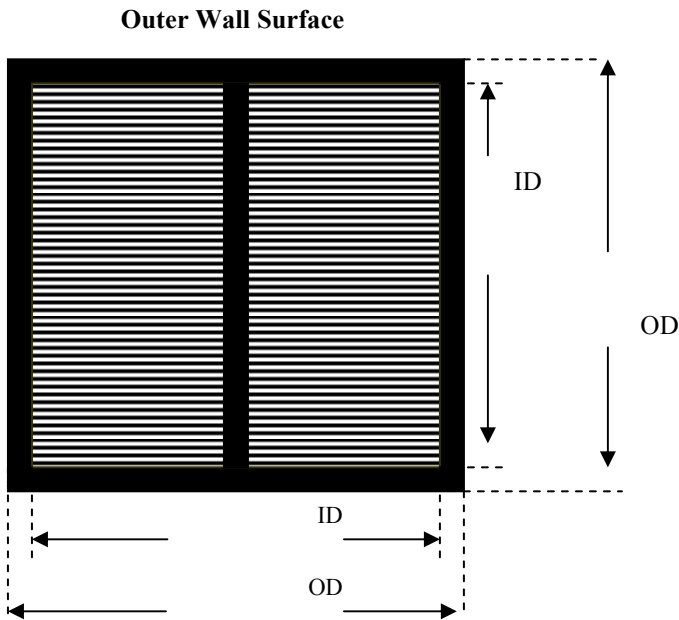

**Notes & Comments:**

Media:

- 3 Dimensional Elecrostatic Polypropylene Media  
 PVC Coated Polyester High Abrasion Media

Fasteners:

- Included  
 Not Included

Dirt, debris and grease are continually coating and insulating your equipment's coils, condensers, electronic systems, motors, fins and other components that fall in the path of the equipment's air intake. Even if foreign objects are not visible, the buildup of airborne particles will impact the equipment's ability to work efficiently and require repeated maintenance for cleaning.

Dirty equipment means efficiency decreases, heat build-ups, higher discharge pressure and increased amp draw. When forced to run for longer cycle times, at reduced capacity, the equipment eventually breaks down, life expectancy decreases and power costs escalate.

## HOW TO MEASURE A PreVent® Model U Filter

PreVent Model U filters are flexible, vinyl edged equipment protection filters. They are manufactured to fit any air intake opening and can include cut outs and unique designs. Model U filters can be attached with hook and loop, grommets or a combination of the two. Attachment should be made on as flat a surface as possible. All filters are manufactured to the EXACT size ordered so measure carefully. Custom filters are not returnable.

Model U filters under 5000 square inches in area are generally fitted with a  $\frac{3}{4}$ " vinyl edge. When measuring for fit over an air intake you must include at least  $\frac{3}{4}$ " additional to the open area on all sides. (In some cases filters will extend more than the vinyl edge past the opening if the attachment surface is further away)

Model U filters over 5000 square inches total area are generally fitted with 2" vinyl edge. When measuring for fit over an air intake you must include at least 2" additional to the open area on all sides.

### Grommets:

When estimating the number of grommets you need to secure a Model U filter the rule of thumb is approximately 12" spacing. Our factory technicians will evenly space the grommets, whatever their number.

To calculate the number of grommets it's easiest to draw a picture so you can easily visualize. Each corner will require a grommet – so you have 4. Use the measurement of each side divided by 12 and round up or down, depending on how close you are to the next whole number.

Example: Side measurement is 100. Divide by 12 and you get 8.33. So you want 8 grommets on that side. Don't forget you already have 1 on each corner so you need 6 additional grommets on that side. Do this for each side and add the total.

### Patterns and Cut Outs:

If you need slits or holes designed into the filter, this is pattern cutting. Draw a picture of the pattern, including all measurements of linear inches which will require vinyl edging. Include any grommets needed to secure filter around pattern.

# Brauer Supply Company

## Custom Filter Order Form

Company Name: _____
Address: _____
City: _____ State: _____ Zip: _____
Contact Name: _____
Phone No: _____
Date: _____ PO# _____

\_\_\_\_ Will Call

\_\_\_\_ Delivery

Location \_\_\_\_\_

Delivery Address \_\_\_\_\_

Special Instructions: \_\_\_\_\_  
 \_\_\_\_\_  
 \_\_\_\_\_  
 \_\_\_\_\_

	QTY	SIZE/ DESCRIPTION/ PART #	EXACT/NOM.	FILTER TYPE (MX, DP, XP, PWG, F/G, ETC)
1.				
2.				
3.				
4.				
5.				
6.				
7.				
8.				

\_\_\_\_ Ship Complete

**THANK YOU FOR YOUR ORDER AND ENJOY YOUR DAY!**



# FILTER SELECTION OPTIONS

## HVAC Applications

Typical Applications	Type of Air Handling Equipment	Typical Air	
		Pre-filters	Product Selection
<b>Residential</b> Apartments, Condominiums Single Family Homes	Room Air Conditioners Residential Furnace & Air Conditioning Units	Not Applicable	Not Applicable
<b>Light Commercial</b> Hotels, Motels (Sleeping Rooms) Light Industrial Nursing Homes Schools (Classrooms) Small Office Buildings	Light Commercial Heating & Air Conditioning Units Packaged Terminal Air Conditioners Unit Ventilators Fan Coil Units	Not Applicable	Not Applicable
<b>Commercial, Industrial, Institutional</b> Airports Auditoriums Banks Bars, Cocktail Lounges Bowling Alleys Casinos Commercial Buildings Correctional Facilities Electric Utilities Food Processing Government Buildings Health Care Facilities Inpatient Care, Administrative, Sterile Processing, Food Processing, Storage, Soiled Holding Areas Hotels (Public Spaces) Industrial Plants - Offices, Plant Air Institutional Facilities Museums Residential (High Rise) Restaurants, Cafeterias Retail Stores, Super Markets Schools, Universities Sports Arenas, Gymnasiums Theaters Train Stations, Bus Depots Warehouses, Storage Areas	Rooftop Air Handling Units Central Station Air Handlers Built Up Frame Banks Side Access Housings	Disposable Panel Filters Pleated Filters Filter Media & Frames Ring Panels, Links Poly Cube Filters Self-Supported Pocket Filters Automatic Roll Filters	Tri-plex 85 DP, DP Max, PowerGuard, DP-g13een, Xtreme+Plus Bio-Pure, StreamLine (Synthetic), Fiberglass Series N, Bio-Pure, Ultra II SynPak Fiberglass, Synthetic
<b>Sensitive Processes</b> Health Care Protective Environment Rooms, Airborne Infection Isolation Rooms, Surgical Suites Labs Microelectronics, Semiconductor Pharmaceutical Production Photo Film Research Facilities Universities	Rooftop Air Handling Units Central Station Air Handlers Built Up Frame Banks Side Access Housings	Disposable Panel Filters Pleated Filters Filter Media & Frames Ring Panels, Links Poly Cube Filters Automatic Roll Filters	Tri-plex 85 DP, DP Max, PowerGuard, DP-g13een, Xtreme+Plus Bio-Pure, StreamLine (Synthetic), Fiberglass Series N, Bio-Pure SynPak Fiberglass, Synthetic

### Ducted Ceiling Modules

- Low profile design - only 5" deep
- Roomside adjustable diffuser
- Anodized extruded aluminum construction



### Legacy® High Efficiency Rigid Cell Extended Surface Filters

- MERV 11 & 15
- Sustainable Component for a LEED/Green Building Initiative



**Legacy® LoadTech™ High Efficiency Rigid Cell Extended Surface Filters**  
 MERV 14  
 Sustainable Component for a LEED/Green Building Initiative



### MicroPleat™ HEPA, ULPA Filters

- 99.99%, 99.999%, 99.9995% efficiencies
- Mini-pleat media pack
- Anodized extruded aluminum cell sides
- All cell side configurations - gasket seal, gel seal, knife edge

### Micro Guard® HEPA, ULPA Filters

- 99.97%, 99.99%, 99.999% efficiencies
- Separator style media pack
- Wood or metal construction
- Individually tested



Filter Products		
	Final Filters	Product Selection
	Disposble Panel Filters Pleated Filters (1") Polyurethane Foam	Trip-plex 85 DP, DP Max, PowerGuard, Xtreme+Plus Poly Foam Permalast
	Disposable Panel Filters Pleated Filters Ring Panel Filters Slip-Ons Filter Media & Frames	Tri-plex 85 DP, DP Max, PowerGuard, Bio-Pure, DP-g13een, Xtreme+Plus Series N, Bio-Pure Slip-Ons StreamLine (Synthetic), Fiberglass
	Extended Surface Pocket Filters (50 - 90%) Extended Surface Rigid Cell Filters (60 - 95%)	Nano-Pak, Defiant, Clean-Pak, Venti-Pak Variflow, Variflow SC, Variflow II, Variflow II-M, Variflow II-MC, Vari+Plus, Vari-Pak, Vari-Pak S, Legacy LoadTech 4", Legacy 4" and 12", Bio-Pure
	Extended Surface Pocket Filters (50 - 90%) Extended Surface Rigid Cell Filters (60 - 95%)  HEPA, ULPA Filters Disposable Ducted Ceiling Modules Replaceable Filter Ceiling Modules Fan / Filter Units	Nano-Pak, Defiant, Clean-Pak, Venti-Pak Variflow, Variflow SC, Variflow II, Variflow II-M, Variflow II-MC, Vari+Plus, Vari-Pak, Vari-Pak S, Bio-Pure Micro Guard (Separator Style), MicroPleat (Mini Pleat) MicroPleat Micro+Plus MicroPleat



**Purolator™ Disposable Panel Filters**

- Fiberglass and synthetic media
- High strength pinch frame construction
- Space saving nested packaging



**Ring Panel Filters**

- Select from four styles
- Tackified media for high dust holding capacity, long service life
- MERV 6 to 7



**Xtreme+Plus® Pleated Filters**

- MERV 8 standard and high capacity
- 100% synthetic media
- Self supported
- Damage resistant
- No metal
- Fully incinerable

**DP-g13een®**

- Pleated Filters**
- LEED/Green Compliant
  - 100% synthetic media
  - MERV 13



**DP® and DP Max Pleated Filters**

- High wet strength beverage board frame
- Durable double wall construction
- Mechanical MERV 8



**PowerGuard® Pleated Filters**

- Highest initial and average efficiency with electrostatically enhanced media
- MERV 11

**Complete Line of Airguard® Bag Filters**

- Nano-Pak®  
Defiant®  
Clean-Pak™  
Venti-Pak®**



**Vari+Plus® VP High Capacity Rigid Cell Filters**

- Mini-pleat media pack design for low resistance
- Rigid all plastic construction
- Dura-Tuff™ 100% synthetic media



**Ultra II Self-Supported Pocket Filters**

- Cube style and multi-pocket models
- Durable, moisture resistant polyester media
- Outstanding service life



**Variflow® High Efficiency Rigid Cell Filters**

- Rigid cell design for difficult operating conditions
- Moisture resistant construction
- Three efficiencies



# Brauer Supply Company General Terms, Conditions, Freight Policies, and Return Policies

(This document is for Reference only. For the latest guidelines, visit [www.brauersupply.com](http://www.brauersupply.com))

## PRICE:

- All orders subject to the prices in effect on the date of shipment or specific quotation.
- All prices and specifications subject to change without notice.

## TERMS:

- 10TH Prox / Net 30 Days from Date of Invoice.
- Payment Discounts, if any, will be shown on the invoice.
- Customer agrees to pay service charges of 1 ½ % per month on all past due accounts.
- Customer agrees to pay a \$30.00 service charge on any and all returned checks.
- Customer agrees to pay any and all costs involved in the recovery of monies owed due to returned checks, past due accounts, or other causes resulting in money owed to Brauer Supply Company. These monies include, but are not limited to the original amounts owed along with collection fees, attorney fees, court costs, and any other fees and/or charges related to the collection of amounts owed.

## MINIMUM BILLING AND SPECIAL ORDERS:

- \$10.00 minimum on all cash and/or check purchases.
- \$20.00 minimum on all charge, CBD, or COD purchases.
- A minimum of 25% deposit will be required on orders for special material.

## SHORTAGES DUE TO BRAUER SUPPLY COMPANY ERROR:

- All claims of shortages, errors, or defective goods must be filed within fifteen (15) days after receipt of material (See below for Return Goods policies related to errors or defective goods).

## WARRANTIES:

- All statements, warranties, and product representations relating to products sold by Brauer Supply Company are those stated on the most current literature from our manufacturers/suppliers. Brauer Supply Company makes no warranties of its own, either expressed or implied.

## LIMITATION OF LIABILITY:

- Brauer Supply Company will not be liable for failure to deliver product to purchaser in a timely fashion for any reason, including, but not limited to, market conditions, product scarcity, failure of manufacturer to meet production schedules, credit decisions, or any other circumstances whether or not under the direct control of Brauer Supply Company, nor will Brauer Supply Company be held liable for any actual, consequential, or liquidated damages resulting from the above conditions. Any provisions, statements, or conditions in purchaser's request-to-quote or purchase order, either written or oral, are hereby specifically rejected.
- Brauer Supply's failure to perform any term or condition of sales agreements as a result of conditions beyond its control, such as, but not limited to, war, strikes, fires, floods, acts of terrorism, civil unrest, acts of God, governmental restrictions, power failures, or damage, failure, or destruction of computer/network systems/facilities/servers, shall not be deemed a breach of those agreements.

## RETURN OF GOODS:

- No goods or materials will be accepted for return without our written consent in the form of an RGA (Return Goods Authorization). This can be expedited by supplying us, via telephone, email, or in writing, with the following information -
  1. Date and number of the invoice on which the material was billed. If material not yet invoiced, the date and number of work order and/or packing list.
  2. Description and quantity of the material being returned.
  3. Reason for the return.
- No material will be accepted for return unless the following conditions are met -
  1. Stock items must have been purchased within 120 calendar days preceding the date of return. If material was defective or shipped incorrectly, Brauer Supply Company must be notified within 15 days of the date on which the material shipped.



## BRAUER SUPPLY COMPANY FREIGHT POLICIES

2. Special items or Brauer Supply non-stock items will not be accepted for return unless our suppliers agree to accept the returned material.
  3. Material must be returned in original cartons and in a resalable condition as determined solely by Brauer Supply Company.
  4. The customer agrees to pay all transportation charges for the return to Brauer Supply Company and/or the manufacturer.
- Once Brauer Supply Company agrees to accept the return, you will receive a written Return Goods Authorization. Upon receipt of the material at Brauer Supply Company or at our supplier as applicable, Brauer Supply Company will credit your account subject to the following terms –
    1. All packing slips and paperwork originating with the customer must reference the Return Goods Authorization number and the date and invoice number (or date and work order / packing slip number if not yet invoiced) on which the material was originally billed (or shipped if not yet invoiced).
    2. Material which can be put back into Brauer Supply Company stock will be credited back at invoice price, less 10% for material returned in full cartons or less 25% for broken cartons.
    3. Special items and Brauer Supply non-stock items for which our suppliers have agreed to accept the return will be credited at invoice price less a pre-agreed restocking charge.
    4. If the return is due to an error by Brauer Supply Company or our supplier, Brauer Supply will either pick up the material, or request that you ship the material to Brauer Supply Company or our Supplier as applicable. Replacement material will be shipped or delivered promptly. Brauer Supply Company or our supplier will pay all freight charges related to the return of defective or incorrect material and the replacement of same with proper material. Replacement material will then be billed in the usual manner.
    5. Any credits due will be applied to open balances for future orders. Cash customers will receive a check or credit card credit issued from our accounting office.
    6. Brauer Supply reserves the right to apply any refund to any outstanding balance that may exist on a customer's account.

### FREIGHT POLICIES AS OF MAY 1, 2013

- All shipments of \$150.00 or more will be shipped freight allowed via our trucks on regularly scheduled days in our regular delivery areas.
- Invoices of less than \$150.00 shipped via Brauer Supply Company vehicles on regularly scheduled days in our regular delivery areas will be subject to a \$25.00 delivery fee.
- Any fuel surcharges in effect will apply to all shipments made via Brauer Supply Company vehicles regardless of order size.
- Contact our office for details on regular delivery schedules and areas.
- Short shipped or backordered items regardless of order size may qualify for freight allowed shipping.
- All orders shipped via UPS or other third party carriers will be sent prepaid, no freight allowed and be subject to an \$8.00 handling charge.
- Orders may be sent 3rd party freight allowed when shipped for Brauer Supply Company's convenience or to fulfill back orders.
- All LTL (less than full truckload) shipped via common carrier will be shipped prepaid, no freight allowed. Freight charges will be billed to customer. Large orders or specifically quoted material may qualify for allowed freight.
- Material shipped direct from one of our manufacturers/suppliers to a customer will be shipped according to their freight policies. Freight charges may be billed to the customer according to such policies.
- Certain material is always shipped no freight allowed. Contact your salesperson or our inside customer service personnel for details.
- When Brauer Supply Company incurs the freight cost, Brauer reserves the right to select the carrier.
- When the customer specifies a carrier or requests expedited delivery/special handling, the customer will be responsible for all freight charges.



# The Complete Industrial Supply House

## Headquarters

1218 South Vandeventer Avenue  
St. Louis, MO 63110  
314-534-7150  
Fax: 314-534-1816

## Union Branch

498 Dubois Valley Drive  
Union, MO 63084  
636-583-8855  
Fax: 636-583-8286

## Insulation Division

1218 South Vandeventer Avenue  
St. Louis, MO 63110  
314-534-7150  
Fax: 314-534-6867

## Joplin Branch

1802 Katherine Street  
Joplin, MO 64801  
417-624-9600  
Fax: 417-624-9602

## Jackson Branch

2652 S Old Orchard Road  
Jackson, MO 63755  
573-243-4877  
Fax: 573-243-9484

## Festus Branch

1014 Airport Road  
Festus, MO 63028  
636-931-8600  
Fax: 636-931-8601

## Columbia Branch

3320 Brown Station Rd  
Columbia, MO 65202  
573-442-1171  
Fax: 573-875-0730

## Springfield, MO Branch

3105-A East Elm  
Springfield, MO 65802  
417-862-7117  
Fax: 417-862-7997

## O'Fallon Branch

1231 Tom Ginnever Avenue  
O'Fallon, MO 63366  
636-978-6700  
Fax: 636-978-6720

## Springfield, IL Branch

1475 Taylor Avenue  
Springfield, IL 62703  
217-544-0265  
Fax: 217-544-0715

## Swansea Branch

105 Service Street  
Swansea, IL 62226  
618-233-1733  
Fax: 618-233-4426

## Kansas City Branch

74 South James Street  
Kansas City, KS 66118  
913-281-3100  
Fax: 913-281-3103